

**भारतीय मानक**

**IS 18255 : 2023**

**Indian Standard**

---

---

**कंक्रीट प्रबलन के लिए काँच रेशा प्रबलित  
(एफआरपी) पॉलिमर के  
सरिए — परीक्षण पद्धतियाँ**

**Fibre-Reinforced Polymer (FRP) Bars  
for Concrete Reinforcement —  
Methods of Test**

ICS 71.140.15; 91.080.40

© BIS 2023



**भारतीय मानक ब्यूरो**  
**BUREAU OF INDIAN STANDARDS**  
मानक भवन, 9 बहादुर शाह ज़फर मार्ग, नई दिल्ली - 110002  
MANAK BHAVAN, 9 BAHADUR SHAH ZAFAR MARG  
NEW DELHI - 110002  
[www.bis.gov.in](http://www.bis.gov.in) [www.standardsbis.in](http://www.standardsbis.in)

**December 2023**

**Price Group 13**

Concrete Reinforcement Sectional Committee, CED 54

## FOREWORD

This Indian Standard was adopted by the Bureau of Indian Standards, after the draft finalized by the Concrete Reinforcement Sectional Committee had been approved by the Civil Engineering Division Council.

This standard has been formulated to cover methods of tests for fibre-reinforced polymer (FRP) bars for use as reinforcement in concrete. FRP bars are used across the world as an alternative to steel bars in reinforced concrete. Recently, India is also witnessing the manufacturing and use of such bars. However, their use in concrete has to be judiciously decided based on the design specifications associated with various physical, chemical and mechanical properties. In order to suitably monitor the quality of such bars manufactured and/or used and to further increase the suitable use of such bars, it was found necessary to bring out a set of test methods in standard conditions, as applicable to the country.

Assistance has been derived from the following standards in the preparation of this standard:

ISO 10406-1 : 2015 Fibre-reinforced polymer (FRP) reinforcement of concrete — Test methods — Part 1: FRP bars and grids

ACI 440.3R-12 Guide test methods for fiber-reinforced polymer (FRP) composites for reinforcing or strengthening concrete and masonry structures

ASTM D2584-18 Standard test method for ignition loss of cured reinforced resins

ASTM D570-22 Standard test method for water absorption of plastics

ASTM D7205/D7205M-21 Standard test method for tensile properties of fiber reinforced polymer matrix composite bars

ASTM D7705/D7705M-12(2019) Standard test method for alkali resistance of fiber reinforced polymer (FRP) matrix composite bars used in concrete construction

ASTM D7913/D7913M-14(2020) Standard test method for bond strength of fiber-reinforced polymer matrix composite bars to concrete by pullout testing

ASTM D7914/D7914M-21 Standard test method for strength of fiber reinforced polymer (FRP) bent bars in bend locations

ASTM E1356-08(2014) Standard test method for assignment of the glass transition temperatures by differential scanning calorimetry

ASTM E2160-04(2018) Standard test method for heat of reaction of thermally reactive materials by differential scanning calorimetry

This standard contributes to the UN Sustainable Development Goal 9 — Industry, innovation and infrastructure: Build resilient infrastructure, promote inclusive and sustainable industrialization and foster innovation.

The composition of the Committee and the Working Group responsible for the formulation of this standard is given in [Annex B](#).

In reporting the result of a test or analysis made in accordance with this standard, if the final value, observed or calculated, expressing the result of a test or analysis, shall be rounded off in accordance with IS 2 : 2022 'Rules for rounding off numerical values (*second revision*)'.

*Indian Standard*

# FIBRE-REINFORCED POLYMER (FRP) BARS FOR CONCRETE REINFORCEMENT — METHODS OF TEST

## 1 SCOPE

**1.1** This standard covers test methods applicable to fibre-reinforced polymer (FRP) bars for use as straight reinforcement and bent bars used as an anchorage for stirrups in concrete structures. This standard also covers the testing of couplers used for FRP bars.

**1.2** This standard does not cover test methods applicable to FRP bars pertaining to pre-stressing applications.

## 2 REFERENCES

The standards listed below contain provisions which through reference in this text, constitute provision of this standard. At the time of publication, the editions indicated were valid. All standards are subject to revision, and parties to agreements based on this standard are encouraged to investigate the possibility of applying the most recent edition of these standards.

<i>IS No.</i>	<i>Title</i>
IS 878 : 2008/ ISO 4788 : 2005	Laboratory glassware — Graduated measuring cylinders ( <i>second revision</i> )
IS 1608 (Part 1) : 2022/ISO 6892-1 : 2019	Metallic materials — Tensile testing: Part 1 Method of test at room temperature ( <i>fifth revision</i> )
IS 1828 (Part 1) : 2022/ISO 7500-1 : 2018	Metallic materials — Calibration and verification of static uniaxial testing machines: Part 1 Tension/compression testing machines — Calibration and verification of the force- measuring system ( <i>fifth revision</i> )
IS 2967 : 1983	Specification for external micrometer ( <i>first revision</i> )
IS 16491 (Part 1) : 2016/ISO 13385-1 : 2011	Geometrical product specifications (GPS) — Dimensional measuring equipment: Part 1 Calipers; design and metrological characteristics

## 3 TERMINOLOGY

For the purpose of this standard, the following definitions shall apply.

**3.1 Alkalinity** — Condition of having or containing hydroxyl (OH<sup>-</sup>) ions; containing alkaline substances.

**3.2 Anchorage Reinforcement** — Latticed or spiral reinforcing steel or FRP bars connected with the anchorage and arranged behind it.

**3.3 Anchoring Section** — End part of a test specimen where an anchorage is fitted to transmit loads from the testing machine to the test section.

**3.4 Average Load** — Average of the maximum and minimum repeated load (stress).

**3.5 Bending Angle** — Angle formed by the straight sections of a test specimen on either side of the deflector.

**3.6 Bend Strength** — Ultimate tensile stress that is carried by the FRP bent bar, provided that failure occurred at the bend.

**3.7 Bend Radius** — Inside radius of the bent FRP bar.

**3.8 Bending Diameter Ratio** — Ratio of the external diameter of the deflector surface in contact with the FRP bar, and the nominal diameter of the FRP bar.

**3.9 Bending Tensile Capacity** — Tensile load at the moment of flexural failure of the test specimen.

**3.10 Characteristic Length** — For bars or tendons that have a repeating surface deformation pattern, it is distance of this pattern, in millimetres. For a spiral pattern, the characteristic length is the pitch.

**3.11 Coefficient of Thermal Expansion** — Average coefficient of linear thermal expansion between given temperatures.

**3.12 Continuous Fibre** — General term for continuous fibres of materials such as carbon, aramid, and glass.

**3.13 Coupler** — Device coupling bars.

To access Indian Standards click on the link below:

[https://www.services.bis.gov.in/php/BIS\\_2.0/bisconnect/knownyourstandards/Indian\\_standards/isdetails/](https://www.services.bis.gov.in/php/BIS_2.0/bisconnect/knownyourstandards/Indian_standards/isdetails/)

**IS 18255 : 2023**

**3.14 Creep** — Time dependent deformation of an FRP bar subjected to a sustained load at a constant temperature.

**3.15 Creep Failure** — Failure occurring in a test specimen due to a sustained load.

**3.16 Creep Failure Capacity** — Load causing failure after a specified period of time from the start of a sustained load.

**3.17 Creep Failure Strength** — Stress causing failure after a specified period of time from the start of a sustained load.

**3.18 Creep Failure Time** — Time between the start of a sustained load and failure of a test specimen.

**3.19 Creep Strain** — Differential change in length per unit length occurring in a test specimen due to creep.

**3.20 Deflected Section** — Section of an FRP bar that is bent and maintained at the required bending angle and bending diameter ratio.

**3.21 Deflector** — Device used to maintain the position, alter the bending angle, or alleviate the stress concentrations in the FRP bar and which is sometimes installed in the deflected section.

**3.22 Fatigue Strength** — Maximum repeated stress at which the test specimen does not fail at the prescribed number of cycles.

**3.23 Fibre-Reinforced Polymer (FRP)** — Composite material, moulded and hardened to the intended shape, consisting of continuous fibres impregnated with a fibre-binding polymer.

**3.24 Frequency** — Number of loading (stressing) cycles per second during the test.

**3.25 FRP Bar** — Composite material formed into a long, slender structural shape suitable for use as reinforcement in concrete and consisting primarily of longitudinal unidirectional fibres bound and shaped by a rigid polymer resin material.

**3.26 Gauge Length** — Straight portion along the length of a test specimen used to measure the elongation using an extensometer or a similar device.

**3.27 Load (Stress) Amplitude** — One-half of the load (stress) ranges.

**3.28 Load (Stress) Range** — Difference between maximum and minimum repeated load (stress).

**3.29 Maximum Repeated Load (Stress)** — Maximum load (stress) during repeated loading.

**3.30 Maximum Tensile Force** — Maximum tensile load sustained by a test specimen during the tensile test.

**3.31 Nominal Cross-Sectional Area** — Value obtained upon dividing the volume of the FRP specimen by its length.

**3.32 Nominal Diameter** — Diameter of FRP bar specimen calculated assuming a circular section.

**3.33 Nominal Peripheral Length** — Peripheral length of the FRP bar specimen that forms the basis for calculating the bond strength and that shall be determined separately for each FRP specimen.

**3.34 Number of Cycles** — Number of times the repeated load (stress) is applied to the test specimen.

**3.35 Repeated Load (Stress)** — Load (stress) alternating cyclically between fixed maximum and minimum values.

**3.36 S-N Curve** — Curve plotted on a graph with repeated stress on the vertical axis and the number of cycles to fatigue failure on the horizontal axis.

**3.37 Tail Length** — The length provided beyond the bend portion of the FRP bent bar.

**3.38 Thermo-Mechanical Analysis (TMA)** — Method for measuring deformation of a material as a function of either temperature or time, by varying the temperature of the material according to a calibrated programme, under a non-vibrating load.

**3.39 TMA Curve** — TMA graph with temperature or time represented on the horizontal axis and deformation on the vertical axis.

**3.40 Ultimate Strain** — Strain corresponding to the maximum tensile force.

#### 4 SYMBOLS AND NOTATIONS

For the purpose of this standard, the symbols and notations shall have the unit and description as given below.

<i>Sl No.</i>	<i>Symbol</i>	<i>Unit</i>	<i>Description</i>
(1)	(2)	(3)	(4)
i)	$A$	mm <sup>2</sup>	Nominal cross-sectional area of test specimen
ii)	$D$	mm	Nominal diameter
iii)	$E$	N/mm <sup>2</sup>	Young's modulus
iv)	$F_u$	N	Maximum tensile force
v)	$f_u$	N/mm <sup>2</sup>	Tensile strength
vi)	$\epsilon_u$	-	Ultimate strain
vii)	$\Delta F$	N	Difference between loads at 20 percent and 50 percent of maximum tensile force
viii)	$\Delta \epsilon$	-	Strain difference between $\Delta F$
ix)	$\tau$	N/mm <sup>2</sup>	Bond stress
x)	$P$	N	Tensile load in the pull-out test
xi)	$u$	mm	Nominal peripheral length of test specimen
xii)	$l$	mm	Bonded length
xiii)	$t$	h	Time
xiv)	$k_a$	-	Empirical constant
xv)	$k_b$	-	Empirical constant
xvi)	$R_{\Delta m}$	percent	Mass loss ratio
xvii)	$V_o$	mm <sup>3</sup>	Volume of water in the measuring cylinder
xviii)	$V_s$	mm <sup>3</sup>	Volume of the sum total of water and test specimen
xix)	$l_o$	mm	Length of test specimen
xx)	$m_1$	g	Mass after immersion
xxi)	$L_1$	mm	Length after immersion
xxii)	$L_t$	mm	Tail length of the FRP bent bars occurring after the bent portion of the bar
xxiii)	$R_{et}$	percent	Tensile capacity retention rate
xxiv)	$F_{u1}$	N	Tensile capacity before immersion
xxv)	$F_{u0}$	N	Tensile capacity after immersion
xxvi)	$R_{yc}$	-	Creep load ratio
xxvii)	$\tau_s$	N/mm <sup>2</sup>	Shear stress
xxviii)	$P_s$	N	Shear failure load
xxix)	$\alpha_{sp}$	1/°C	Coefficient of thermal expansion
xxx)	$\Delta L_{spm}$	mm	Difference in length of test specimen between temperature $T_1$ and $T_2$
xxxi)	$\Delta L_{refm}$	mm	Difference in length of test specimen for length calibration between temperatures $T_1$ and $T_2$
xxxii)	$L_0$	m	Length of test specimen at room temperature
xxxiii)	$T_g$	°C	Glass transition temperature
xxxiv)	$T_e$	°C	Extrapolated end temperature — the point of intersection of the tangent drawn at the point of greatest slope on the transition curve with the extrapolated baseline following the transition
xxxv)	$T_f$	°C	Extrapolated onset temperature — the point of intersection of the tangent drawn at the point of greatest slope on the transition curve with the extrapolated baseline prior to the transition
xxxvi)	$T_i$	°C	Inflection temperature — the point on the thermal curve corresponding to the peak of the first derivative (with respect to

**IS 18255 : 2023**

<i>Sl No.</i>	<i>Symbol</i>	<i>Unit</i>	<i>Description</i>
xxxvi	$T_m$	°C	Midpoint temperature — the point on the thermal curve corresponding to 1/2 the heat flow difference between the extrapolated onset and extrapolated end
xxxvi	$T_o$	°C	Temperature of first deviation — the point of first detectable deviation from the extrapolated baseline prior to the transition
xxxix	$T_r$	°C	Temperature of return to baseline — the point of last deviation from the extrapolated baseline beyond the transition.
xl)	$T_2$	°C	Maximum temperature for calculation of coefficient of thermal expansion (normally 60 °C)
xli)	$T_1$	°C	Minimum temperature for calculation of coefficient of thermal expansion (normally 0 °C)
xlii)	$\alpha_{set}$	1/°C	Coefficient of thermal expansion calculated for specification test specimen for length calibration between temperatures $T_1$ and $T_2$

**5 GENERAL PROVISIONS CONCERNING TEST SPECIMENS**

For the tests given in this standard, the following provisions concerning test specimens shall apply:

- a) Test specimens shall be taken from the bar in the “as-delivered” condition;
- b) When test specimens are taken from a coil, they shall be straightened prior to any test by a simple bending operation without significant plastic deformation;
- c) For the determination of the mechanical properties in the tensile, bond, and anchorage tests, the test specimen may be artificially aged (after straightening, if applicable) depending on the performance requirements of the product; and
- d) When a test specimen is “aged”, the conditions of the ageing treatment and its relevance to the expected field conditions shall be stated in the test report.

**6 TEST METHOD FOR DETERMINATION OF FIBRE MASS FRACTION AND INORGANIC FILLER CONTENT BY IGNITION LOSS OF CURED GLASS-REINFORCED RESINS**

**6.1 General**

This test method can be used to obtain the ignition loss of a cured reinforced resin sample (bar specimen). This test method does not provide a measure of resin content for samples containing reinforcing materials (such as carbon and aramid fibres) that may lose weight under the conditions of

the test or containing resins or fillers that do not decompose to volatile materials released by ignition.

**6.2 Test Specimens**

The test specimen shall be approximately 1 cm long and weigh approximately 5 g to 20 g ( $W_1$ ). The number of test specimens shall be at least three, taken from the as-produced bar of the same lot. The test specimens shall be stored carefully and protected against deformation, heating, and exposure to ultraviolet light, which can cause changes to the material properties of the test specimens.

**6.3 Test Equipment**

- a) *Crucible*, platinum or porcelain, approximately 30 ml capacity; and
- b) *Electric muffle furnace*, capable of maintaining a temperature of 565 °C ± 28 °C.

**6.4 Test Procedure**

- a) Measure the length of the specimen using a vernier caliper;
- b) Conduct tests in the standard laboratory atmosphere of 27 °C ± 2 °C and (65 ± 5) percent relative humidity;
- c) Heat the crucible at 500 °C to 600 °C for 10 min or more. Cool to room temperature in a desiccator and weigh to the nearest 1 mg;
- d) Place the specimen in the crucible and weigh to the nearest 1 mg. Heat the crucible and specimen in a muffle furnace at a

temperature  $565\text{ }^{\circ}\text{C} \pm 28\text{ }^{\circ}\text{C}$ . Maintain such a temperature that the specimen burns at a uniform and moderate rate until only ash and glass fibres remain when the burning ceases;

- e) Care shall be taken that the ignition does not proceed so rapidly that there is a mechanical loss of the non-combustible residue;
- f) Heat the crucible and residue in the muffle furnace at  $565\text{ }^{\circ}\text{C} \pm 28\text{ }^{\circ}\text{C}$  until all carbonaceous material has disappeared. Cool the crucible to room temperature in a desiccator and weigh to the nearest 1 mg;

NOTE — The time for the carbonaceous residue to disappear depends largely on the specimen geometry. It can be up to 6 h, but is usually much less.

- g) Allow the crucible and residue to reach a constant weight within 1 mg on subsequent measurements. Record the measured weight as the total weight of glass fibres and inorganic fillers ( $W_2$ ); and
- h) Keep the residue in a clean stainless steel sieve with a mesh opening size of 50 microns. Wash the residue with slowly running water, keep the residue in an oven at  $100\text{ }^{\circ}\text{C}$  until a constant weight within 1 mg is attained. Weigh the material retained in the sieve and record as fibre mass content ( $W_3$ ). The weight of filler can be obtained by subtracting  $W_3$  from  $W_2$ .

## 6.5 Calculations

Calculate the ignition loss of the specimen, in weight percent as per equation (1),

Ignition loss, weight percent

$$= \left[ \frac{W_1 - W_2}{W_1} \right] \times 100 \quad \dots (1)$$

where

$W_1$  = weight of specimen, in g; and

$W_2$  = weight of residue, in g.

Average the ignition loss values obtained as above for the three specimens to obtain the average ignition loss of the sample.

Subtract the lowest specimen ignition loss from the highest specimen ignition loss for the sample tested, and report as the ignition loss range.

The inorganic filler fraction (IFF) can be obtained by equation (2),

$$\text{IFF} = \left[ \frac{W_2 - W_3}{W_1} \right] \quad \dots (2)$$

where

$W_3$  = fibre mass content, in g.

The polymer fraction,  $PF$ , is equal to the average ignition loss which is obtained as above.

The fibre fraction,  $FF$ , is given by equation (3),

$$FF = 1 - PF - IFF \quad \dots (3)$$

## 6.6 Test Report

The test report shall include the following items:

- a) Name, shape, date of manufacture, and lot number of FRP bar specimen tested;
- b) Type of fibre and fibre binding polymer;
- c) Ignition loss (weight percent) of individual specimens, average, and standard deviation;
- d) Fibre fraction;
- e) Inorganic filler content; and
- f) Observations in regard to any irregularities noted in the physical properties of the residue, such as melting.

## 7 TEST METHOD FOR DETERMINATION OF GLASS TRANSITION TEMPERATURE OF RESIN USED

### 7.1 Test Specimens

**7.1.1** The specimen shall weigh approximately 5 mg to 20 mg. The test specimens shall be stored carefully and protected against deformation, heating, and exposure to ultraviolet light, which can cause changes to the material properties of the test specimens. The number of test specimens shall be at least three, taken from the as-produced bar of the same lot.

**7.1.2** Test specimen shall be prepared as follows:

- a) Prepare a hardened resin sample by mixing resin and hardener as per manufacturer's recommendations;
- b) Cut the hardened resin sample to an appropriate size and desired mass;
- c) Report any mechanical or thermal pretreatment; and
- d) An amount of reference material with a heat capacity closely matched to that of the specimen may be used. An empty specimen pan may also be adequate.

## IS 18255 : 2023

### 7.2 Test Equipment

- a) *Differential scanning calorimeter (DSC)* — The essential instrumentation required includes a test chamber composed of a furnace(s) to provide uniform controlled heating (cooling) of a specimen and reference to a constant temperature or at a constant rate over the temperature range from - 120 °C to 500 °C; a temperature sensor to provide an indication of the specimen temperature to  $\pm 0.1$  °C; differential sensors to detect heat flow difference between the specimen and reference; a means of sustaining a test chamber environment of a purge gas of 10 to 100 ml/min within 4 ml/min; a temperature controller, capable of executing a specific temperature program by operating the furnace(s) between selected temperature limits at a rate of temperature change of up to 20 °C/min constant to  $\pm 0.5$  °C/min. The output should include signals of heat flow, temperature and time.
- b) *Containers such as pans, crucibles, and vials.*
- c) *Analytical balance*, with a capacity more than 100 mg, capable of weighing to nearest 0.01 mg.

### 7.3 Test Procedure

- a) If appropriate, perform and record an initial thermal program in flowing nitrogen or air environment using a heating rate of 10 °C/min to a temperature at least 20 °C above  $T_e$  to remove any previous thermal history (see [Fig. 1](#)).
- b) Midpoint temperature is most commonly used as the glass transition temperature (see [Fig. 1](#)).
- c) Hold temperature until an equilibrium as indicated by the instrument response is achieved.
- d) Set the cooling rate to 20 °C/min and allow the specimen to attain a temperature of 50 °C below the transition temperature of interest.
- e) Hold temperature until an equilibrium as indicated by the instrument response is achieved.
- f) Repeat heating at the same rate as in SI No. (a) and record the heating curve until all desired transitions have been completed.

### 7.4 Calculations

Determine the temperatures  $T_m$  (preferred),  $T_f$ , and  $T_i$  (see [Fig. 1](#)).

where

- $T_m$  = midpoint temperature, in °C;
- $T_f$  = extrapolated onset temperature, in °C; and
- $T_i$  = inflection temperature, in °C.

Increasing the heating rate produces greater baseline shifts thereby improving detectability. In the case of DSC, the signal is directly proportional to the heating rate in heat capacity measurements. Recheck the specimen mass to ensure that no loss or decomposition has occurred during the measurement.

### 7.5 Test Report

The test report shall include the following items:

- a) Name, shape, date of manufacture, and lot number of FRP bar tested;
- b) Type of fibre and fibre binding polymer;
- c) Description of instrument used for the test;
- d) Statement of the dimensions, geometry, and material of the specimen holder;
- e) Scan rate, in °C/min;
- f) Description of temperature calibration procedure;
- g) Results of the transition measurements using temperature parameters ( $T_g$ , etc) cited in [Fig. 1](#), or any combination of parameters that were chosen; and
- h)  $T_g$  (half extrapolated heat capacity temperature is preferred).

## 8 TEST METHOD FOR DETERMINATION OF WATER ABSORPTION

### 8.1 Test Specimens

**8.1.1** Bar specimens shall be 25 mm long for diameters up to 25 mm and 15 mm long for diameters larger than 25 mm. The specimens shall be measured to the nearest 0.1 mm. The cut edges shall be made smooth by finer sandpaper or emery cloth. Sawing, machining, and sandpapering operations shall be slow enough so that the material is not heated appreciably.

**8.1.2** The number of test specimens shall be at least three, taken from the mother material of the same lot.

**8.1.3** The test specimens shall be carefully stored and protected against deformation, heating, and exposure to ultraviolet light, which can cause changes to the material properties of the test specimens.

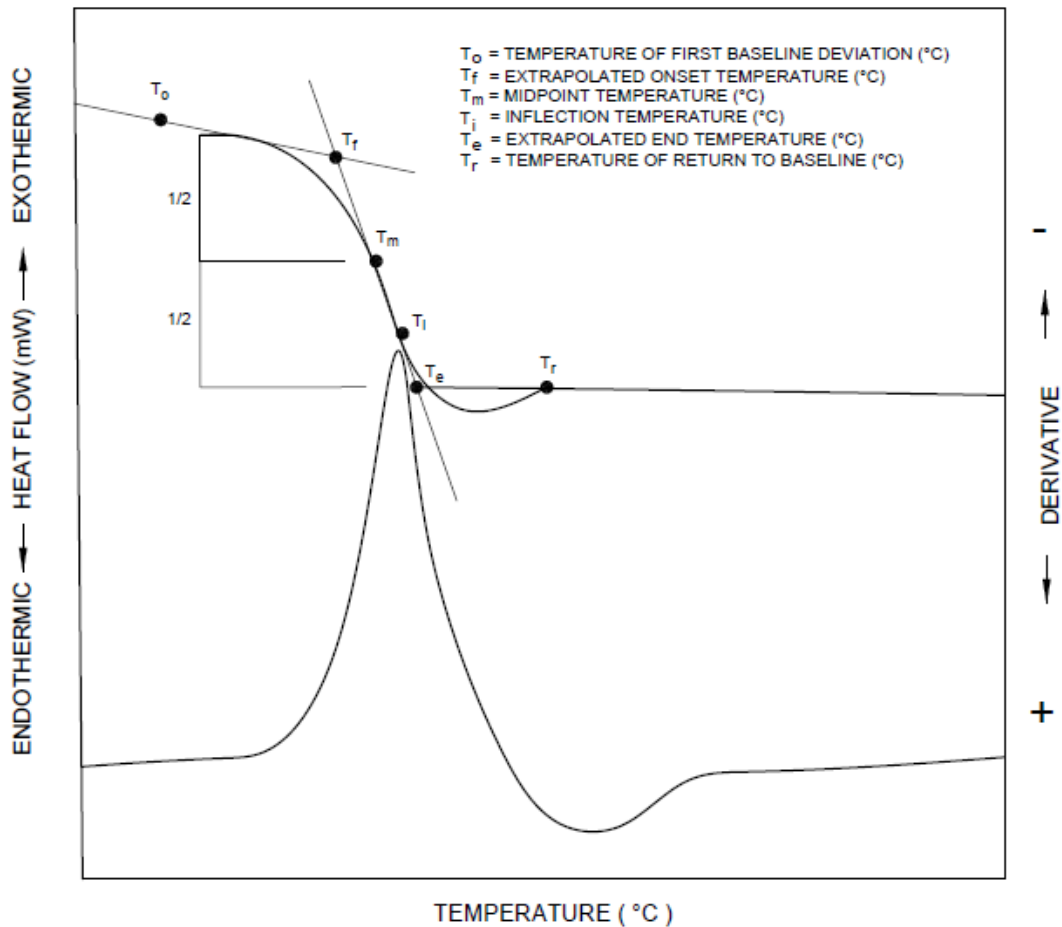

FIG.1 TYPICAL GRAPH SHOWING THE MEASURED TEMPERATURES AT THE GLASS TRANSITION REGION

## 8.2 Test Procedure

### 8.2.1 Conditioning

Specimens of materials whose water absorption value would be appreciably affected by temperatures in the neighbourhood of  $110^{\circ}\text{C}$ , shall be dried in an oven for 24 h at  $50^{\circ}\text{C} \pm 3^{\circ}\text{C}$ , cooled in a desiccator, and immediately weighed to the nearest 0.001 g.

### 8.2.2 Twenty-Four Hour Immersion

The conditioned specimens shall be placed in a container of distilled water maintained at a temperature of  $27^{\circ}\text{C} \pm 2^{\circ}\text{C}$ , and shall rest on edge and be entirely immersed. At the end of  $24\text{ h} \pm 0.5\text{ h}$ , the specimens shall be removed from the water one at a time, all surface water wiped off with a dry cloth, and weighed to the nearest 0.001 g immediately.

### 8.2.3 Repeated Immersion

A specimen may be weighed to the nearest 0.001 g after 2 h immersion, replaced in the water, and

weighed again after 24 h.

NOTE — In using this test method, the amount of water absorbed in 24 h may be less than it would have been had the immersion not been interrupted.

### 8.2.4 Long-Term Immersion

To determine the total water absorbed when substantially saturated, the conditioned specimens shall be tested as described in 8.2.2, except that at the end of 24 h they shall be removed from the water, wiped free of surface moisture with a dry cloth, weighed to the nearest 0.001 g immediately, and then replaced in the water. The weighing shall be repeated at the end of the first week and every two weeks thereafter until the increase in weight per two-week period, as shown by three consecutive weighing, averages less than 1 percent of the total increase in weight or 5 mg, whichever is greater. The specimen shall then be considered substantially saturated. The difference between the substantially saturated weight and the

## IS 18255 : 2023

dry weight shall be considered as the water absorbed when substantially saturated.

### 8.2.5 Re-conditioning

When materials are known or suspected to contain any appreciable amount of water-soluble ingredients, the specimens, after immersion, shall be weighed, and then reconditioned for the same time and temperature as used in the original drying period. They shall then be cooled in a desiccator and immediately reweighed. If the reconditioned weight is lower than the conditioned weight, the difference shall be considered as water-soluble matter lost during the immersion test. For such materials, the water-absorption value shall be taken as the sum of the increase in weight on immersion and of the weight of the water-soluble matter.

## 8.3 Calculation

**8.3.1** Percentage increase in weight during immersion, calculated to the nearest 0.01 percent is given by equation (4),

Increase in weight, in percent

$$= \frac{\text{wet weight} - \text{conditioned weight}}{\text{conditioned weight}} \times 100 \dots(4)$$

**8.3.2** Percentage of soluble matter lost during immersion, if determined, calculated to the nearest 0.01 percent is given by equation (5),

Soluble matter lost, in percent

$$= \frac{\text{conditioned weight} - \text{reconditioned weight}}{\text{conditioned weight}} \times 100 \dots(5)$$

When the weight on reconditioning the specimen after immersion in water exceeds the conditioned weight prior to immersion, 'none' shall be reported under [8.4 \(h\)](#).

**8.3.3** For long-term immersion procedure only, prepare a graph of the increase in weight as a function of the square root of each immersion time. The initial slope of this graph is proportional to the diffusion constant of water in the plastic. The plateau region with little or no change in weight as a function of the square root of immersion time represents the saturation water content of the plastic.

NOTE — Deviation from the initial slope and plateau model indicates that simple diffusion may be a poor model for determining water content. In such cases, additional studies are suggested to determine a better model for water absorption.

**8.3.4** The percentage of water absorbed shall be calculated as the sum of the values obtained in [8.3.1](#) and [8.3.2](#).

## 8.4 Test Report

The test report shall include the following items:

- a) Name, shape, date of manufacture, and lot number of FRP bar specimen tested;
- b) Type of fibre and fibre binding polymer;
- c) Dimensions of the specimens before test;
- d) Conditioning time and temperature;
- e) Immersion procedure used;
- f) Time of immersion (long-term immersion procedure only);
- g) Percentage increase in weight during immersion; and
- h) Percentage of soluble matter lost during immersion.

## 9 TEST METHOD FOR DETERMINATION OF DEGREE OF CURE

### 9.1 Principle

This test method determines the exothermic heat of reaction of thermally reactive chemicals or chemical mixtures, using milligram specimen sizes, by differential scanning calorimetry. This test method also determines the extrapolated onset temperature and peak heat flow temperature for the exothermic reaction. The applicable temperature range of this test method is 25 °C to 600 °C.

### 9.2 Test Specimens

Prepare a resin sample of 1 mg to 2 mg by extracting from the bar. Care should be taken to avoid the presence of fibres in the collected sample. The number of test specimens shall be at least three, taken from the as produced bar of the same lot. Store the test specimens carefully and protect against deformation, heating, and exposure to ultraviolet light, which can cause changes to the material properties of the test specimens.

NOTE — Because of the reactive nature of the materials examined by this test method, small specimen sizes shall be used unless the approximate activity of the test specimen is known.

### 9.3 Test Apparatus

- a) *Differential scanning calorimeter (DSC)*, capable of measuring and recording heat flow as a function of temperature and time shall be used. The apparatus shall also comprise of a test chamber with,
  - 1) *Furnace(s)*, to provide uniform controlled heating of a specimen and reference to a constant temperature or at

a constant rate within the temperature range of 25 °C to 600 °C.

- 2) *Temperature sensor*, to provide an indication of the specimen or furnace temperature with  $\pm 0.5$  °C accuracy.
- 3) *Differential sensor*, to detect a heat flow difference between the specimen and reference, equivalent to 0.2 mW.
- 4) *Means of sustaining a test chamber environment*, of inert (for example, nitrogen, helium or argon) or reactive (for example, air) gas at a purge rate of 50 ml/min  $\pm$  5 ml/min.

NOTE — Typically, at least 99 percent pure nitrogen, helium or argon is employed when oxidation in air is a concern. Unless effects of moisture are to be studied, use of dry purge gas is recommended.

- 5) *Temperature controller*, capable of executing a specific temperature program by operating the furnace(s) between selected temperature limits (ambient temperature to 600 °C) at a heating rate between 2 °C/min and 20 °C/min constant to within  $\pm 0.1$  °C/min.
  - 6) *Recording device*, capable of recording and displaying any portion (including signal noise) of the differential heat flow on the ordinate as a function of temperature or time on the abscissa.
- b) *Containers (pans, crucibles, vials, etc and lids)*, that are inert to the specimen and reference materials, and that are of suitable structural shape and integrity to contain the specimen and reference in accordance with the specific requirements of this test method.
  - c) *Balance*, with a capacity of 100 mg or greater to weigh specimens and containers, or both to a sensitivity of  $\pm 1$   $\mu$ g.

#### 9.4 Test Procedure

- a) Into a tared sample container, weigh to within  $\pm 1$   $\mu$ g, 1 mg to 2 mg of the test specimen. Record this mass as *m*, in mg. Close the sample. Weigh the sealed container to within  $\pm 1$   $\mu$ g and record this mass as *m*<sub>cured</sub>, in mg.

##### NOTES

**1** Some substances may have non-reactive components mixed with the thermally reactive material. An example would be the case of fibres mixed with a thermally-curing polymer. A specification of the fraction of inert material in the mixture may accompany these materials. Such specifications may involve tolerances so that the actual fraction of inert material may vary within these tolerances from lot to lot. In such cases, the actual fraction of inert material shall be taken into account.

**2** For highly reactive materials, the selection of sample containers can be particularly important. The material from which the container is constructed may catalyze the reaction or react with the sample material. Sealed containers may cause an autocatalytic effect or possibly a pressure effect. Loss of material, and thereby loss of heat, could be an issue in open containers. Excessive pressurization of sample container can be avoided by using vented containers. However, vented or unsealed containers may cause the measured heat of reaction to be much smaller than the true value.

**3** The use of this test method for materials of unknown potential hazards requires that precautions be taken during the sample preparation and testing. Where particle size reduction by grinding is necessary, the user of this test method shall presume that the material is hazardous. Toxic or corrosive effluents, or both, may be released when heating the test specimen and could be harmful to personnel or the apparatus. Use of an exhaust system to remove such effluents is recommended.

- b) Heat the test specimen at a controlled rate of 10 °C/min  $\pm$  0.1 °C/min from ambient temperature until the thermal curve returns to baseline following the exothermic event. If the upper limit of temperature for this test method, that is, 600 °C, is reached before the thermal curve returns to baseline, then this test method is not applicable. Other heating rates may be used, but shall be reported.
- c) Cool the test specimen to ambient temperature upon completion of the experiment.
- d) Re-weigh the sample container. Compare this mass of the sealed sample container weight with *m*<sub>cured</sub> determined in [9.4 \(a\)](#). Report any specimen weight loss observed.
- e) Construct a line connecting the baseline before the exothermic reaction to that after the reaction (*see* [Fig. 2](#)).

NOTE — For highly energetic reactions, a significant change may occur in the baseline prior to and following the exothermic reaction, due to a significant change in the heat capacity of the reacted material in the sample container. Such an instance might be handled by the construction of a baseline that is not a straight line. If a nonlinear baseline (for example, a sigmoidal baseline) is used, it should be stated in the report and an example of the constructed baseline and the thermal curve should be also included.

- f) Integrate the area, as a function of time, bounded by the thermal curve and the baseline constructed in [9.4 \(e\)](#). Record this area as the heat of the reaction, *A*, in mJ.

##### NOTES

**1** The area bounded by the thermal curve and the constructed baseline gives the heat of the reaction. Instrument software is most often used to integrate this area. Although such software packages display thermal curves as in [Fig. 2](#), they calculate the bound area on a basis of time. If older instruments without these software

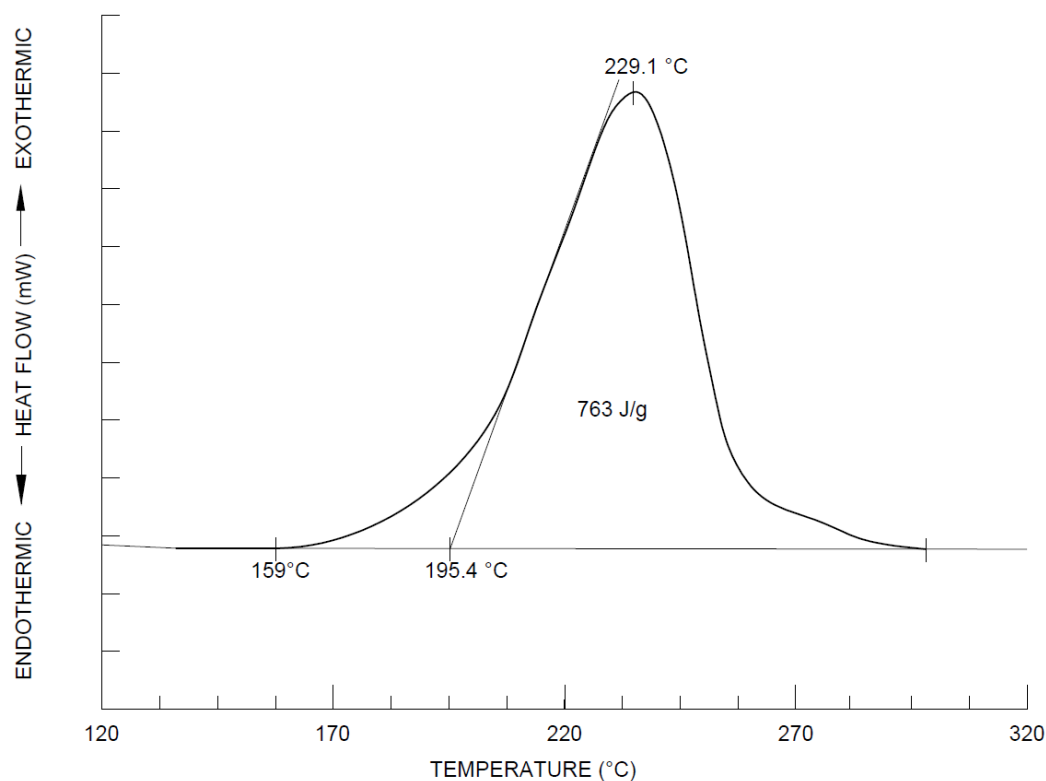

FIG. 2 THERMAL CURVE, DETERMINATION OF REPORTED VALUES

packages are used, or if manual checks are performed on newer instruments, then the manual integration shall be performed with the abscissa presented as a time (seconds) coordinate.

2 The amount of material should be chosen such that the maximum heat flow is less than 8 mW. If heat flow is larger than 8 mW and the peak is not 'leaning' and not following the trend in Fig. 3, it should not be necessary to reduce sample mass or, in other words, when both directions cannot be met simultaneously, sample mass need to be reduced only if the observed peak leans.

- g) Construct a tangent to the leading edge of the exothermic peak at the point of maximum rate of change and extrapolate that tangent to the baseline constructed in 9.4 (e). Record the intersection of the tangent with the baseline as the onset temperature,  $T_{o,DC}$ .

NOTE — In some cases, reactions may have induction periods or other effects that are manifested as exothermic deviations from the established baseline well before the onset temperature obtained by 9.4 (g). Because of the importance of these effects for highly reactive materials, an additional onset temperature, the temperature of first deviation ( $T_{f,DC}$ ), is to be reported also. The temperature of first deviation is the temperature for which the thermal curve first deviates from the established baseline. The temperature of first

deviation is to be noted in the report. Peak temperatures from two different determinations are comparable only if the same conditions were used for both measurements for example, sample mass and vent diameter.

- h) Record the temperature at the maximum deflection from the baseline constructed in 9.4 (e) as the peak temperature,  $T_{p,DC}$ .

### 9.5 Calculations

- a) Normalized heat of reaction of the resin collected from the bar,  $H_{cured}$ , is calculated by dividing the heat of reaction,  $A_{cured}$  obtained from 9.4 (f) by the specimen mass,  $m_{cured}$  obtained from 9.4 (a), as given in equation (6),

$$H_{cured} = \frac{A_{cured}}{m_{cured}} \quad \dots (6)$$

- b) Performing this test on a virgin resin specimen that is completely unreacted, produces the total heat of reaction,  $H_{uncured}$ , calculated using equation (7) as given below:

$$H_{uncured} = \frac{A_{uncured}}{m_{uncured}} \quad \dots (7)$$

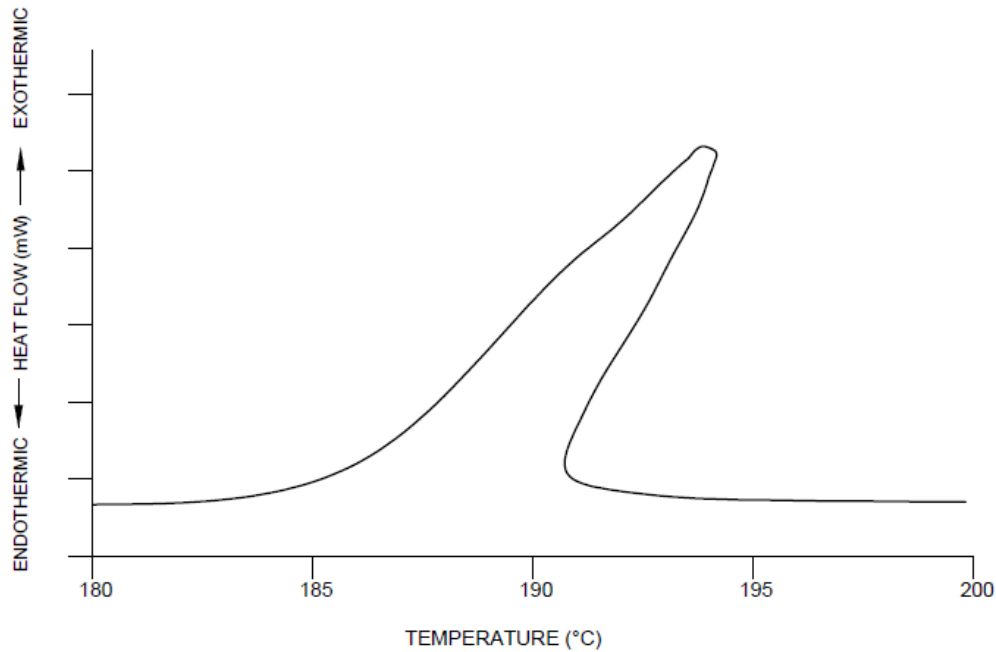

FIG. 3 EXAMPLE OF A LEANING THERMAL CURVE RESULTING FROM TOO MUCH MATERIAL IN THE SAMPLE PAN

- c) The degree of cure,  $DC$ , is the percent of fraction reacted, given by equation (8),

$$DC = \left(1 - \frac{H_{\text{cured}}}{H_{\text{uncured}}}\right) \times 100 \quad \dots (8)$$

### 9.6 Test Report

The test report shall include the following items:

- Name, shape, date of manufacture, and lot number of FRP bar sample tested;
- Type of fibre and fibre binding polymer;
- Heating rate, temperature range, purge gas type and rate, and specimen container type and material used;
- Extrapolated onset temperature ( $T_{o,DC}$ ), the peak temperature ( $T_{p,DC}$ ), the temperature of first deviation ( $T_{f,DC}$ ), and the normalized and total heat of reaction ( $H_{\text{cured}}$  and  $H_{\text{uncured}}$ , respectively);
- Fraction reacted or the degree of cure ( $DC$ ) of the reaction; and
- Any specimen weight loss observed.

## 10 TEST METHOD FOR CROSS-SECTIONAL PROPERTIES

### 10.1 Test Specimens

- Test specimens shall be cut to a predetermined length and finished flat at

their cut end from the mother material (FRP bars) for tensile test;

- The length of test specimens shall be 100 mm when approximate nominal diameter is 20 mm or less, and shall be 200 mm when approximate nominal diameter is more than 20 mm; and
- At least five test specimens shall be taken from the mother material of the same lot.

### 10.2 Test Procedure

- Measure the length of the test specimen using the vernier calipers in accordance with IS 16491 (Part 1). Measure a part and record the result to three places; round off the three averaged values to one place after the decimal point. Take this as the length of the test specimen.
- Measure the volume of the test specimen using a measuring cylinder in accordance with IS 878, Type 1a or 1b (class A or class B), according to the approximate diameter of the test specimen. [Table 1](#) shows the relationship between the approximate diameter of the test specimen and the capacity of the measuring cylinder. When two capacities are listed, choose the smaller-capacity cylinder for that range.

**IS 18255 : 2023**

- c) Add the proper quantity of water (so that the test specimen can be fully immersed) to the measuring cylinder and measure the volume. When the test specimen is fully immersed, the top of the water shall be within the range of scale.

NOTE — If air bubbles are generated on the surface of the test specimen, which can cause an error of measurement, a surface-tension reducing solvent, such as ethanol, can be added to the water for the purpose of controlling the generation of air bubbles.

- d) Insert the test specimen into the measuring cylinder and measure the volume of the combined water and the test specimen.
- e) The test temperature shall be within the range of 20 °C to 30 °C.

**10.3 Calculations**

- a) Calculate the nominal cross-sectional area,  $A$ , of the test specimen from equation (9) given below and round off to one place after the decimal point:

$$A = \frac{V_s - V_o}{l_o} \quad \dots (9)$$

where

- $l_o$  = Length of the test specimen, expressed in mm;
- $V_o$  = Volume of water in the measuring cylinder, in mm<sup>3</sup>; and
- $V_s$  = Volume of the sum total of water and test specimen, in mm<sup>3</sup>.

NOTE — The nominal cross-sectional area includes the area of surface-bonded sand particles, surface-bonded transverse wraps, and other non-load-bearing areas.

Calculate the nominal diameter,  $D$ , from equation (10)

given below and round off to one place after the decimal point:

$$D = 2\sqrt{\frac{A}{\pi}} \quad \dots (10)$$

where  $A$  is the nominal cross-sectional area, in mm<sup>2</sup>.

Obtain the fibre fraction and polymer fraction as per [6](#).

**10.4 Test Report**

**10.4.1 Mandatory Information**

The test report shall include the following items:

- a) Date of testing;
- b) Name, shape, date of manufacture, and lot number of FRP bars tested;
- c) Nominal cross-sectional area;
- d) Nominal diameter;
- e) Fibre fraction;
- f) Polymer fraction; and
- g) Strength of fibre (as reported by the manufacturer).

**10.4.2 Additional Information**

The test report may include the following additional items:

- a) Capacity of measuring cylinder used in the test;
- b) Length of test specimen;
- c) Volume of water in the measuring cylinder;
- d) Combined volume of water and test specimen in the measuring cylinder; and
- e) Name and proportion of the solvent, if any solvent is used in the test.

**Table 1 Relationship Between the Approximate Diameter of Test Specimen and the Capacity of Measuring Cylinder**

[[Clause 10.2 \(b\)](#)]

Sl No.	Approximate Diameter of Test Specimen	Capacity of Measuring Cylinder
	mm	ml
(1)	(2)	(3)
i)	Less than 10	10 to 25
ii)	11 to 13	25
iii)	14 to 20	50 to 100
iv)	21 to 25	100
v)	More than 25	250 to 500

## 11 TEST METHOD FOR TENSILE PROPERTIES

### 11.1 Test Specimens

- Length of test specimens shall be taken to be the sum of the length of the test section,  $L$  and the length of the anchoring section,  $L_g$  at two ends (see Fig. 4). The length of the test section shall be not less than 300 mm and not less than 40 times the nominal diameter;
- The test specimens shall be cut to predetermined length in such a way as not to affect the performance of the part being tested;
- The test specimens shall be stored carefully and protected against deformation, heating, and exposure to ultraviolet light, which can cause changes to the material properties of the test specimens; and
- At least five test specimens shall be tested.

### 11.2 Test Equipment

- The testing machine should conform to the requirements for the tension-testing machine in accordance with IS 1828 (Part 1).
- The anchorage shall be suited to the geometry of the test specimens and shall have the capacity to transmit only the tensile force along the longitudinal axis of the test specimens. FRP bars shall be properly anchored prior to the tensile testing to avoid premature failure of FRP bars at the junctions. Guidelines for anchoring FRP bars using steel anchors as given in Annex A shall be followed.
- The extensometers and strain gauges used to measure the elongation of the test specimen under loading shall be capable of recording variations in the gauge length or elongation during testing with an accuracy of at least  $10^{-5}$ . The gauge length,  $L_{ga}$  of the extensometer shall be not less than 100 mm and not less than 8 times the nominal diameter of the FRP bar (see Fig. 4).

### 11.3 Test Procedure

- Mount the test specimen on the testing machine, such that only the axial load is transmitted (see Fig. 5).
- Mount the extensometer along the axis of the central portion of the test specimen.
- Load the test specimen in accordance with the following requirements:

- Apply the load at a constant rate without impact to the test specimen. The rate of loading shall be 0.5 percent to 1.5 percent strain per minute. The test time shall not exceed 5 min.
- Measure the strain at not fewer than 10 equally spaced loading increments until approximately two-thirds of the maximum tensile force.
- Record the maximum tensile force with a precision of three significant digits.
- The test temperature shall be within the range of 5 °C to 35 °C.

### 11.4 Calculations

#### 11.4.1 General

All results, except when for the cases where the location of the failure position is within anchorage, shall be used as a rule. However, if the failure location is often found to be within anchorage, the results of the failure within anchorage may only be included. In cases when a result (in terms of the maximum tensile force) deviates by 10 percent or more from the average value, that result shall be ignored and only the four remaining results shall be used. In such cases, if one result deviates by 10 percent or more from the average value calculated using the four results, all results shall be rejected, and a new test shall be performed. Rejected test results shall not be used for the calculation of tensile rigidity, Young's modulus, or ultimate strain. The average,  $\bar{x}$ , deviation,  $\Delta x_i$ , and standard deviation,  $\sigma$ , are defined as given in the equations (11) to (13), respectively:

$$\bar{x} = \frac{1}{N} \sum_{i=1}^N x_i \quad \dots (11)$$

$$\Delta x_i = x_i - \bar{x} \quad \dots (12)$$

$$\sigma = \sqrt{\frac{1}{N} \sum_{i=1}^N (x_i - \bar{x})^2} \quad \dots (13)$$

where

$N$  = number of test specimens; and  
 $x_i$  = sampling data.

The cross-sectional area shall be the nominal cross-sectional area calculated in accordance with equation (9).

#### 11.4.2 Tensile Strength

Calculate the tensile strength,  $f_u$ , expressed in N/mm<sup>2</sup>, to a precision of two significant digits using equation (14),

IS 18255 : 2023

$$f_u = F_u/A \quad \dots (14)$$

where

$F_u$  = maximum tensile force, in N; and

$A$  = nominal cross-sectional area, in mm<sup>2</sup>.

11.4.3 Tensile Rigidity and Young's Modulus

Calculate the tensile rigidity,  $E_A$ , in N and Young's modulus,  $E$ , in N/mm<sup>2</sup>, both to a precision of two significant digits, using equations (15) and (16), respectively. It shall be calculated from the difference between the load (stress-strain) curve obtained from the load level at 20 percent and 50 percent of the tensile capacity. If a guaranteed tensile capacity is given, the values at 20 percent and 50 percent of the guaranteed tensile capacity may be used.

$$E_A = \frac{\Delta F}{\Delta \epsilon} \quad \dots (15)$$

$$E = \frac{\Delta F}{\Delta \epsilon \times A} \quad \dots (16)$$

where

$\Delta \epsilon$  = strain difference for  $\Delta F$ ; and

$\Delta F$  = difference between loads at 20 percent and 50 percent of the maximum tensile force, in N.

11.4.4 Ultimate Strain

Ultimate strain,  $e_u$ , shall be the strain corresponding to the ultimate tensile capacity when strain gauge measurements of the test specimen are available up to failure. In the event that the measurements from

an extensometer or strain gauge are not available up to failure, the ultimate strain,  $e_u$ , shall be calculated to a precision of three significant digits using equation (17),

$$e_u = \frac{F_u}{E \times A} \quad \dots (17)$$

11.5 Test Report

The test report shall include the following items:

- a) Date of testing;
- b) Name, shape, date of manufacture, and lot number of FRP bar specimen tested;
- c) Type of fibre and fibre binding polymer;
- d) Numbers or identification marks of test specimens;
- e) Designation, nominal cross-sectional area, diameter, fibre fraction, polymer fraction, and strength of fibre;
- f) Temperature, loading rate;
- g) Individual, average and COV of the tensile force and tensile strength;
- h) Individual, average and COV of tensile rigidity and Young's modulus;
- j) Individual, average and COV of ultimate strain and ultimate strain;
- k) Stress-strain curve for each test specimen;
- m) Mode of failure for each test specimen; and
- n) Name of person in-charge carrying out the test.

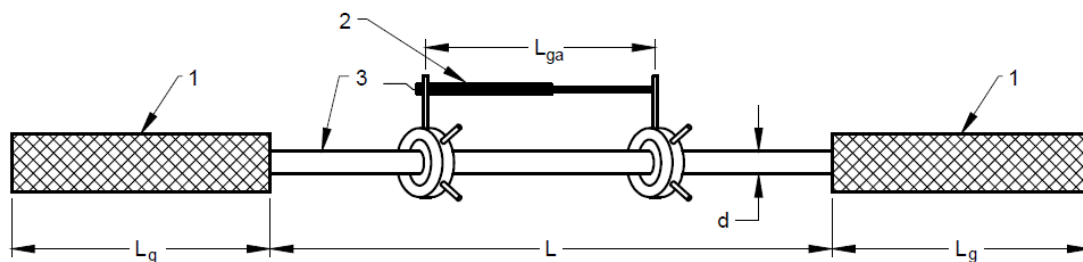

Key

- 1 Anchoring section
- 2 Extensometer
- 3 Test section

FIG. 4 TEST SPECIMEN FOR TENSILE TEST

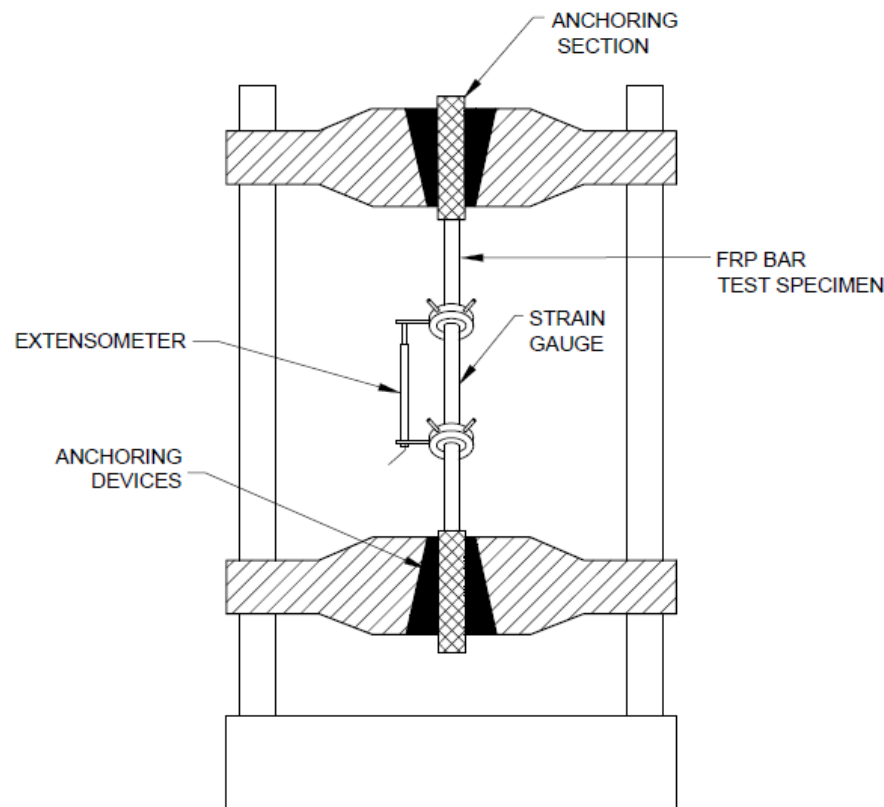

FIG. 5 OUTLINE OF TENSILE TEST

## 12 TEST METHOD FOR BOND STRENGTH BY PULL-OUT TESTING

### 12.1 Test Specimen

- a) The provisions of FRP bar test specimens given in [11](#) shall apply;
- b) The bond test specimens may be fabricated as follows:
  - 1) Test specimens should normally be cubes, with a single FRP bar embedded vertically along the central axis (see [Fig. 6](#)).
  - 2) The bonded length of the FRP bar shall be a typical section of the surface of the FRP bar and shall be located at the free-end side of the test specimen. The bonded length of the FRP bar shall be four times the nominal diameter of the FRP bar. In order to equalize the stress from the loading plate on the loaded side, the embedded bar outside the bonded section shall be sheathed with PVC or other suitable material to prevent bonding. The dimensions of the test specimen shall be determined as a function of the nominal diameter of the

FRP bars as shown in [Table 2](#).

- 3) The FRP bar shall be allowed to protrude by around 10 mm at the free-end side and its end face shall be structured so as to allow the attachment of a dial gauge, etc, for measuring the length of pull-out. The loading end of the FRP bar shall be extended sufficiently to allow the pull-out test to be carried out, and shall be fitted with an anchoring section, gripping device, or similar apparatus capable of transmitting axial loads to the FRP bar. The FRP bar shall be arranged on the central axis of the test specimen.
- 4) Test specimens can be provided with spiral reinforcements along the central axis to prevent splitting failure. Spiral reinforcements shall be 6 mm in diameter, with a spiral pitch of 40 mm. The external diameter of spiral reinforcement is dependent on the nominal diameter of the FRP bars as specified in [Table 2](#). The ends of the spiral reinforcements shall be welded, or 1.5 times extra turns shall be provided.

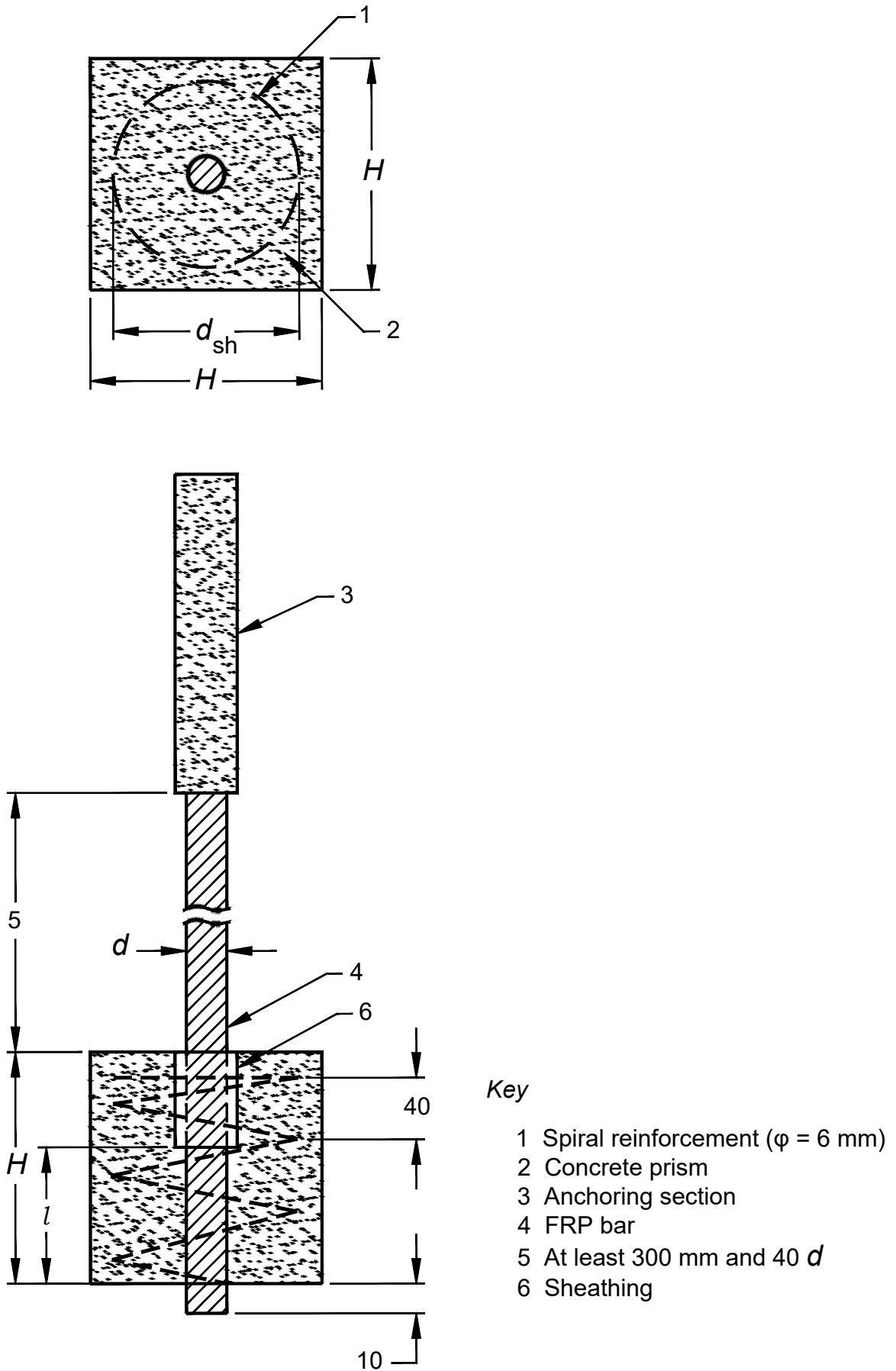

where,  $l = \text{bonded length} = 4 d$ .

All dimensions in millimetres.

FIG. 6 TEST SPECIMEN FOR BOND STRENGTH TEST (PULL-OUT TEST)

**IS 18255 : 2023**

- c) Standard concrete shall be prepared for bond testing. The concrete shall be made with normal aggregates, with the coarse aggregates having a maximum dimension of 20 mm. The concrete shall have a slump of 100 mm  $\pm$  20 mm, and an average 28 day cube compressive strength of 40 N/mm<sup>2</sup>  $\pm$  3 N/mm<sup>2</sup> (a minimum of three cubes shall be tested for calculating the average value). The bond test specimen shall be cast as follows:
- 1) Clean the bonding section of the FRP bar and render it free from any grease, dirt, etc.
  - 2) Take suitable measures before placing the concrete to prevent bonding of the non-bonding or sheathed sections of the FRP bar.
  - 3) Seal the opening in the form through which the FRP bar is inserted to prevent ingress/egress of water, etc, using oil, putty, or similar material.
  - 4) Smooth off the test specimen after placing the concrete by scraping any excess off the top, repeating this process again after about 2 h to ensure that a test specimen with the proper dimensions is obtained.
  - 5) Remove the forms after two days and then cure the test specimens in water at a temperature of 27 °C  $\pm$  2 °C until the time of testing.
- d) Test at least three test specimens. When a test specimen fails at, or slips out of the anchoring section, carry out an additional test on a separate test specimen prepared using FRP bars from the same lot as the failed test specimen.

**12.2 Testing Equipment**

- a) The testing machine for pull-out tests shall be capable of accurately applying the prescribed load.
- b) The loading plate shall have a hole through which the FRP bar shall pass. The diameter of the hole in the loading plate shall be two times to three times the diameter of the FRP bar.
- c) The loading-end side of the FRP bar shall be fitted with an anchorage capable of transmitting loads accurately until the tendon pulls out due to bond failure, or because of splitting or cracking of the concrete. The load-transmission device shall transmit only axial loads to the FRP bar, without transmitting either torsional or flexural forces.
- d) The displacement meter fitted to the free end of the FRP bar shall be a linear variable differential transformer (LVDT) or any similar apparatus capable of giving readings with an accuracy of 1/1 000 mm (see Fig. 7).

**12.3 Test Procedure**

- a) The age of the test specimens at the time of testing shall be 28 days;
- b) The test specimen shall be placed correctly on the loading plate with a swivel setup to prevent eccentric loads from acting on the test specimens (see Fig. 7);
- c) The standard loading rate shall be such that the average tensile stress of the FRP bar increases at a rate of 10 N/mm<sup>2</sup>/min to 20 N/mm<sup>2</sup>/min. The loading rate shall be kept as constant as possible so as not to subject the test specimens to shock; and

**Table 2 Dimensions of Test Specimens**

[Clause 12.1 (b) (2)]

SI No.	Nominal Diameter, <i>d</i> mm (2)	Size of Cube mm (3)	Bonded Length mm (4)	External Diameter of Spiral Reinforcement, <i>d<sub>sh</sub></i> mm (5)
i)	$\leq 16$	100 $\times$ 100 $\times$ 100	4 $\times$ nominal diameter	$80 \leq d_{sh} \leq 100$
ii)	$> 16$ to $\leq 25$	150 $\times$ 150 $\times$ 150	4 $\times$ nominal diameter	$120 \leq d_{sh} \leq 150$
iii)	$> 25$ to $\leq 32$	225 $\times$ 225 $\times$ 225	4 $\times$ nominal diameter	$120 \leq d_{sh} \leq 150$

**IS 18255 : 2023**

- d) The slippage of the free end and the load applied shall be recorded in increments as shown in [Table 3](#), until either the FRP bar pulls out of the concrete or the load decreases significantly due to the splitting or cracking of the concrete.

**12.4 Calculations**

- a) When a test specimen is judged to have undergone tensile failure at the anchoring section or to have slipped out of the anchoring section before the FRP bar slips from the concrete or the load is significantly reduced due to splitting or cracking of the concrete, reject the data and carry out additional test(s) until the number of test specimens slipping from the concrete or where the load is significantly reduced due to splitting or cracking of the concrete is not fewer than three.
- b) Calculate the bond stress,  $\tau$ , in N/mm<sup>2</sup>, to a precision of three significant digits using equation (18), and plot the curve for the pull-out load or bond stress versus slippage displacement for each test specimen.

$$\tau = \frac{P}{u \times l} \quad \dots (18)$$

where

- $P$  = tensile load in the pull-out test, in N; and
- $u$  = nominal peripheral length of test specimen, in mm ( $= \pi d$ , where  $d$  is the nominal diameter of the bar); and
- $l$  = bonded length, in mm;

**12.5 Test Report**

The test report shall include the following items:

- a) Name, shape, date of manufacture, and lot number of the FRP bar tested;

- b) Type of fibre and fibre-binding polymer, type of surface treatment of fibres;
- c) Numbers or identification marks of test specimens;
- d) Designation, nominal cross-sectional area, and diameter;
- e) Date of test, test temperature, loading rate;
- f) Dimensions of test specimens, bonded length of the FRP bar;
- g) Concrete mix, slump, and compressive strength at time of testing;
- h) Average and maximum bond stress, and failure mode for each test specimen; and
- j) Bond stress versus slippage displacement curve for each test specimen.

**13 TEST METHOD FOR TENSILE CAPACITY OF COUPLERS**

**13.1 Test Specimens**

- a) For couplers, follow the setup in [Fig. 8](#). Prepare test specimens by attaching FRP bars on both sides of the coupler specimen to be tested to one of the ends of the two FRP bars on either side of the coupler. The other ends of the bars should be attached to anchors suited to the geometry of the FRP bars and shall have the capacity to transmit only the tensile force along the longitudinal axis of the FRP bar;
- b) The recommended length of FRP bar between abutments is 3 m. However, when shorter lengths are used, the length of FRP bars between anchorages shall not be less than 300 mm nor less than 40 times the nominal diameter;

**Table 3 Measurement Increments**

[[Clause 12.3 \(d\)](#)]

Sl No.	Slippage of Free End	Measurement Increment
	mm	mm
(1)	(2)	(3)
i)	< 0.1	0.01
ii)	0.1 to 0.2	0.02
iii)	0.2 to 0.5	0.05
iv)	> 0.5	0.1

- c) The FRP bars used shall have an axial capacity larger than the desired or rated capacity of the coupling devices; and
- d) At least five test specimens shall be tested.

### 13.2 Test Procedure

- a) The ambient test temperature should generally be within the range of 5 °C to 35 °C. For cases with a significantly different field temperature, it is recommended to perform tests with a temperature similar to the field temperature.
- b) Mount and support the test specimens on the tensile testing machine. Determine the area and geometry of the surface supporting the anchorage, the tension in the FRP bars, and the manner of application of forces that represents the actual structural conditions;

- c) The standard loading rate shall be a constant strain rate equivalent to 1 percent strain per minute  $\pm$  0.5 percent;
- d) Continue loading up to the tensile failure, as determined either by the failure of the FRP bar or by the excessive deformation of the coupling device. In case of the failure of the FRP bar, the coupling device can be rated satisfactory for use with the FRP bar used. In any case, the coupler should not fail at a load less than the minimum rated capacity;
- e) The failed coupler should be visually assessed for deformations of the thread; and
- f) The percent elongation of the coupler at failure load shall be reported by following the procedures in IS 1608 (Part 1).

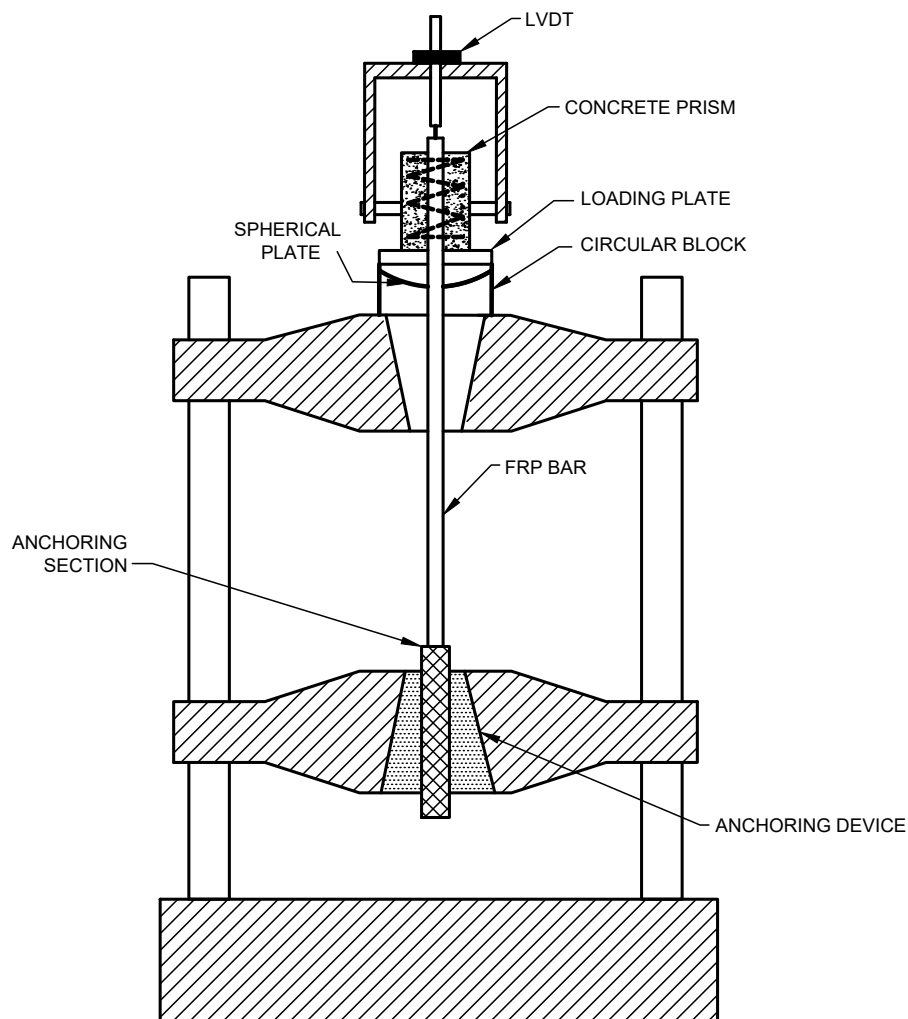
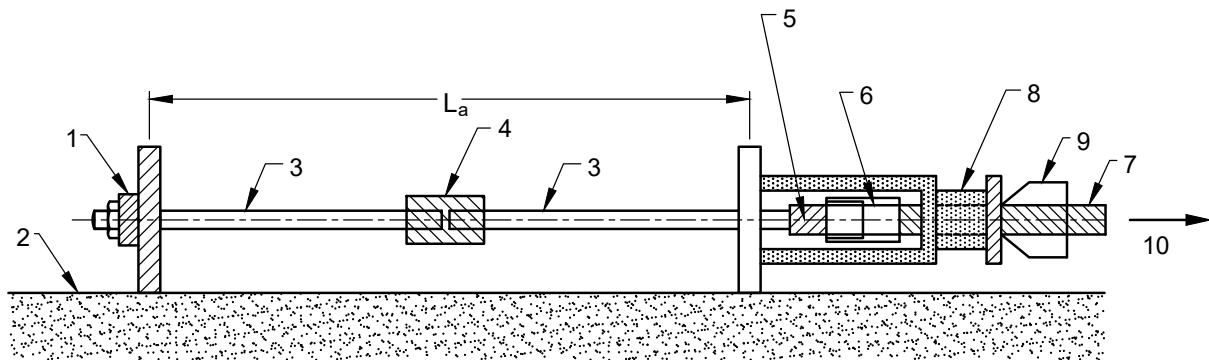

FIG. 7 OUTLINE OF BOND TEST (PULL-OUT TEST)

IS 18255 : 2023



where,  $L_a$  = length of FRP bar between abutments which is equal to 3.0 m.

**Key**

- 1 Anchorage
- 2 Abutment
- 3 FRP bar
- 4 Coupler (test specimen)
- 5 Anchoring section
- 6 Coupler
- 7 Prestressing FRP bar
- 8 Load cell
- 9 Prestressing jack
- 10 Force

FIG. 8 OUTLINE OF TEST FOR PERFORMANCE OF COUPLER

**13.3 Calculations**

Calculate the tensile capacity and percent elongation at failure load for each test specimen and the average and coefficient of variation. Also, record the modes of failure, noting any deformation, damage, caving in, etc, of the coupler.

**13.4 Test Report**

The test report shall include the following items:

- a) Name and lot number of FRP bar tested;
- b) Type of fibre and fibre-binding material;
- c) Numbers or identification marks of test specimens;
- d) Designation, nominal cross-sectional area, and diameter;
- e) Date of test, ambient test temperature, loading rate;
- f) Dimensions of test specimens and description of coupler;
- g) Average tensile failure capacity of all the test specimens, and tensile failure capacity and failure mode for each test specimen; and

- h) Records of any deformation, damage, caving in, etc, of anchorages and couplers.

**14 TEST METHOD FOR TENSILE FATIGUE**

**14.1 Test Specimens**

- a) Preparation, handling, and dimensions of test specimens shall be in accordance with the provisions in [11](#).
- b) Test at least five test specimens for each of the five load levels. If a test specimen fails at or slips out of the anchoring section, an additional test should be carried out on a separate test specimen taken from the same lot as the failed test specimen.
- c) Disregard data for test specimens that slipped from the anchoring section in assessing the material properties of FRP bars. In cases where tensile failure or slippage has clearly taken place at the anchoring section, disregard the data. Additional tests shall be carried out until the number of test specimens failing in the test section is not fewer than five.

### 14.2 Test Equipment

- a) The testing machine shall be capable of maintaining a constant load (stress) amplitude, maximum and minimum repeated load (stress) and frequency. The testing machine shall be fitted with a counter capable of recording the number of cycles to failure of the test specimen. The load indicator should be capable of measuring loads with an accuracy of not less than 1 percent of the load range;
- b) The anchorage shall be in accordance with the provisions in [11](#). Ideally, the same type of anchorage shall be used for all test specimens in a given series of tests; and
- c) If strain measurements are required as part of the fatigue tests, an extensometer and strain gauge capable of maintaining an accuracy of  $\pm 1$  percent of the indicated value during the test shall be used. The extensometer should allow a gauge length that includes an integer number of characteristic lengths of the specimen. The integer should be at least two, but possibly greater than two to obtain a gauge length of at least 50 mm.

### 14.3 Test Procedure

- a) The test temperature should generally be within the range 5 °C to 35 °C. The specified test temperature for test specimens sensitive to temperature variations shall be  $27\text{ °C} \pm 2\text{ °C}$ . For cases with a significantly different field temperature, it is recommended to perform tests at a temperature similar to the field temperature.
- b) Mounting of test specimens shall be in accordance with the provisions in [11](#);
- c) For the purpose of determining an S-N curve, set the maximum and minimum loads by one of the following three methods:
  - 1) Fix the average load and vary the load amplitude,
  - 2) Fix the minimum load and vary the maximum load, and

- 3) Fix the load ratio and vary the maximum and minimum load according to this fixed ratio.
- d) Determine the method adopted according to the purpose of the test. In any case, at least five load levels shall be set such that the range of number of cycles to failure is between  $10^3$  to  $2 \times 10^6$ . Typical S-N curves for FRP materials are generated using the method given in SI No. (c) and utilize a fixed load (stress) ratio, R, of 0.1;
- e) The loading frequency should normally be within the range of 1 Hz to 10 Hz;
- f) Start of test — After static loading up to the average load, commence repeated loading. Introduce the prescribed load rapidly and without any shock. The maximum and minimum repeated loads shall not change for the duration of the test. Counting of the number of cycles should normally commence when the load on the test specimen has reached the prescribed maximum load;
- g) End of test — Complete separation (breaking) of the test specimen shall be deemed to constitute failure; record the number of cycles to failure. If the test specimen does not fail after  $2 \times 10^6$  cycles, the test may be discontinued. Do not reuse test specimens that did not fail; and
- h) Interruption of test — Tests should normally be conducted without interruption for each test specimen from the start to the end of the test. When a test is interrupted, record the number of cycles up to the time of interruption and the period of the interruption.

### 14.4 Calculations

- a) Plot the S-N curve with the maximum repeated stress, stress range, or stress amplitude represented on an arithmetic scale along the vertical axis, and the number of cycles to failure represented on a logarithmic scale along the horizontal axis. Where measurement points coincide, note the number of coinciding points. Add right-facing arrows to indicate points representing test results for remaining test specimens that did not fail.

## IS 18255 : 2023

- b) Derive the fatigue strength at  $2 \times 10^6$  cycles by interpolation on an S-N curve obtained by one of three load selection methods mentioned earlier [see 14.3 (c)]. Report the fatigue strength to a precision of two significant digits.

### 14.5 Test Report

The test report shall include the following items:

- a) Name, shape, date of manufacture, and lot number of FRP bar tested;
- b) Type of fibre and fibre-binding material;
- c) Numbers or identification marks of test specimens;
- d) Designation, nominal cross-sectional area, and diameter;
- e) Date of test, test temperature, and humidity (from start to end of test);
- f) Maximum load (stress), minimum load (stress), load range (stress range), number of cycles up to failure and frequency rate for each test specimen;
- g) The time of interruption and the period of interruption, if any;
- h) Record of observed failure mode for each test specimen; and
- j) S-N curve and fatigue strength.

## 15 TEST METHOD FOR ALKALI RESISTANCE

### 15.1 Test Specimens

- a) Do not subject the test specimens to any processing before testing;
- b) Store the test specimens and protect against all deformation, heating, and exposure to ultraviolet light, which can cause changes to the material properties of the test specimens during sampling and preparation of test specimens;
- c) The length of the test section shall not be less than 100 mm, nor less than 40 times the nominal diameter (excluding the ribs) of the FRP bar; and
- d) Test at least five test specimens each for pre- and post-immersion tensile testing. In the event that a test specimen fails at, or slips out of the anchoring section, an additional test should be carried out on a separate test specimen taken from the same lot as the failed test specimen.

### 15.2 Test Equipment

- a) The alkaline solution for immersion can be made by dissolving 8 g of NaOH and 22.4 g of KOH in 1 litre of deionized water. This solution shall have the similar chemical composition as concrete pore solution and an initial pH of above 13; and
- b) *Immersion apparatus* — An alkali resistant (say, acrylic) container with holes at the side face through which the bars can be inserted/placed. The space between the bars and the side plate can be sealed with an alkali resistant sealant. Then the container can be filled with solution so that the portion of the bars inside the container is immersed in solution (see Fig. 9).

### 15.3 Test Procedure

#### 15.3.1 Immersion in Alkaline Solution

- a) Record the pH of the alkaline solution at the beginning of the immersion test.
- b) In order to prevent the infiltration of the solution via the ends of the test specimens during immersion, coat both ends of the test specimens with epoxy resin and allow to cure.
- c) The specified temperature for immersion shall be  $60 \text{ }^\circ\text{C} \pm 3 \text{ }^\circ\text{C}$ . This shall be ensured and monitored on a daily basis.
- d) Mount the test specimen on the immersion apparatus. Cover the container with plastic sheet/cover to prevent evaporation during immersion test.
- e) Record the pH of the alkaline solution at 28, 56, 60 and 90 days. No significant change is expected, if properly covered during the immersion test.
- f) Wash the test specimen in water after 90 days of immersion.

#### 15.3.2 Change in Appearance and Mass of the Test Specimen

- a) Examine the external appearance of the test specimen before and after the immersion test, for comparison of colour, surface condition, and change of shape. If necessary, the test specimen may be sectioned and polished, and the condition of the cross-section examined using a microscope.
- b) After immersion, remove the epoxy resin from the ends of bar; dry the test specimen and measure the mass until the mass is

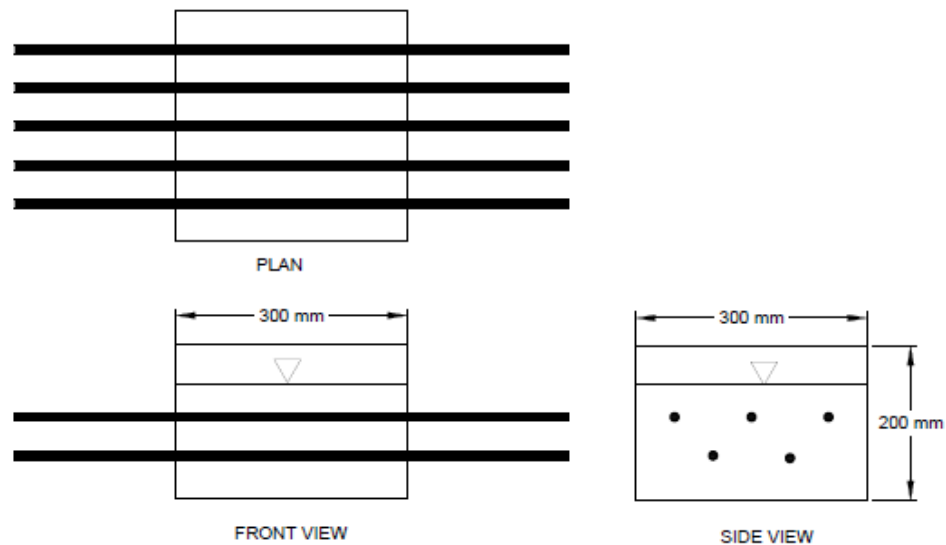

FIG. 9 TEST SETUP FOR IMMERSION TEST

constant. Calculate the rate of percentage mass loss,  $R_{\Delta m}$ , using equation (19) as follows.

$$R_{\Delta m} = \left[ \frac{(m_0/L_0) - (m_1/L_1)}{m_0/L_0} \right] \times 100 \dots (19)$$

where

- $L_0$  = length before immersion, in mm;
- $L_1$  = length of test specimen from which both ends have been removed after immersion, in mm;
- $m_0$  = mass before immersion, in g; and
- $m_1$  = mass after immersion, in g.

### 15.3.3 Tensile Test

- a) The test temperature and test method shall be in accordance with the provisions in [11](#); and
- b) Testing machine and devices shall be in accordance with the provisions in [11](#).

### 15.4 Calculations

- a) Assess the material properties of FRP bar only on the basis of test specimens undergoing failure in the test section. If tensile failure or slippage takes place at the anchoring section, disregard the data. Additional tests should be carried out until the number of test specimens failing in the test section is not less than five.

- b) Calculate the tensile capacity retention rate,  $R_{et}$ , expressed in percent, with a precision to two significant digits according to equation (20),

$$R_{et} = \frac{F_{u1}}{F_{u0}} \times 100 \dots (20)$$

where

- $F_{u1}$  = tensile capacity after immersion, in N; and
- $F_{u0}$  = tensile capacity before immersion, in N.

### 15.5 Test Report

The test report shall include the following items:

- a) Basic information:
  - 1) Name, shape, date of manufacture, and lot number of FRP bar tested;
  - 2) Type of fibre and fibre-binding material;
  - 3) Fibre fraction;
  - 4) Polymer fraction;
  - 5) Strength of fibre;
  - 6) Numbers or identification marks of test specimens;
  - 7) Designation, nominal cross-sectional area, and diameter; and
  - 8) Date of start and end of immersion.

## IS 18255 : 2023

- b) Information related to alkaline exposure test:
- 1) Composition of alkaline solution, pH, temperature, immersion period, and time;
  - 2) Tensioning load and ratio of tensioning load to nominal tensile capacity (if tensioning is not carried out, this fact should be noted); and
  - 3) Record of observation of external appearance and rate of mass loss.
- c) Information related to tensile test:
- 1) Test temperature and loading rate;
  - 2) Average and standard deviation of the tensile capacity (strength) for immersed and non-immersed tests, and tensile capacity for each immersed and non-immersed test specimen;
  - 3) Ultimate strain for all immersed and non-immersed test specimens, and average ultimate strain;
  - 4) Tensile capacity retention rate; and
  - 5) Stress-strain curve for all immersed and non-immersed test specimens.

## 16 TEST METHOD FOR CREEP FAILURE

### 16.1 Test Specimens

- a) Test specimen shall be prepared and handled in accordance with the provisions in [11](#).
- b) Test at least five test specimens for each test condition. If a test specimen fails at, or slips out of the anchoring section, an additional test should be carried out on a separate test specimen taken from the same lot as the failed test specimen.

### 16.2 Test Equipment

- a) The testing frame and devices shall be capable of maintaining constant and sustained load, even if the test specimen deforms.
- b) The anchorage shall be in accordance with the provisions in [11](#).
- c) The extensometer and strain gauge shall be in accordance with the provisions in [11](#).

- d) The passage of time during the test shall be measured with appropriate equipment (timer, etc) with an accuracy of within 1 percent of the elapsed time.

### 16.3 Test Procedure

- a) The ambient temperature should be within the range of  $27\text{ }^{\circ}\text{C} \pm 2\text{ }^{\circ}\text{C}$ . For cases with a significantly different field temperature, it is recommended to perform tests at a temperature similar to the field temperature.
- b) The tensile capacity shall be calculated in accordance with the provisions in [11](#).
- c) Mounting of the test specimens and gauge length shall be in accordance with the provisions in [11](#).
- d) Loading:
  - 1) Take care during loading to prevent the test specimen from being subjected to any shock or vibration;
  - 2) Perform the loading promptly and record the initial loading time;
  - 3) Creep test measurement is considered to start at the moment when the prescribed loading to the test specimens has been completed; and
  - 4) The creep force shall not be allowed to decrease by 2 percent or more from the nominal force.
- e) Selection of sustained loads to be applied:
  - 1) Conduct the creep tests for not less than five sets of load values, selected on the basis of the tensile capacity. The five load values can be obtained by multiplying the five load ratios of 0.2, 0.35, 0.5, 0.65, and 0.8 with the average tensile capacity obtained in accordance with the provisions in [11](#); and
  - 2) One set of load value shall be such that five test specimens do not fail after 1 000 h of loading.
- f) Measurement of creep strain: Creep strain shall be recorded automatically by a recorder attached to the testing machine. If no recorder is attached to the testing machine, measure and record the creep strain after the following times have elapsed: 1 min, 3 min, 6 min, 9 min, 15 min, 30 min, 45 min, 1 h, 1.5 h, 2 h, 4 h, 10 h, 24 h, 48 h, 72 h, 96 h, and 120 h; and subsequently, record a minimum of one measurement every 120 h.

## 16.4 Calculations

- Assess the material properties of FRP bars only on the basis of test specimens undergoing failure in the test section. If tensile failure or slippage has clearly taken place at the anchoring section, disregard the data; additional tests should be carried out until the number of test specimens failing in the test section is not fewer than five.
- Disregard data of test specimens breaking at the start of loading. In such cases, record only the applied load and the creep failure time, but exclude them from the data; it is not necessary to perform additional tests.
- For each test specimen subjected to creep test, the load ratio/creep-failure time curve shall be plotted on a semi-logarithmic graph where the load ratio is represented on an arithmetic scale along the vertical axis and the creep-failure time, expressed in hours, is represented on a logarithmic scale along the horizontal axis.
- Prepare a creep-failure line chart based on the creep load ratio,  $R_{Yc}$ , and calculate the best-fit line for the graphed data using the least-squares method according to equations (21) and (22),

$$R_{Yc} = k_a - k_b \cdot \log t \quad \dots (21)$$

where

$k_a$  and  $k_b$  = empirical constants; and  
 $t$  = time, in h.

The coefficient of determination,  $r^2$ , is calculated using equation (22),

$$r^2 = 1 - \frac{\sum_{i=1}^n [R_{Yci} - (k_a - k_b \cdot \log t_i)]^2}{\sum_{i=1}^n (R_{Yci} - \bar{R}_{Yc})^2} \quad \dots (22)$$

## 16.5 Test Report

The test report shall include the following items:

- Name, shape, date of manufacture, and lot number of FRP bar tested;
- Type of fibre and fibre-binding material;
- Numbers or identification marks of test specimens;
- Designation, nominal cross-sectional area, and diameter;
- Date of test, test temperature;
- Type and name of testing frame and devices;
- Type and name of anchorage;
- Average tensile capacity and tensile capacity (strength) for each test specimen;
- Initial loading time;
- Load ratio/creep failure time curve;
- Creep strain/time curve for each test specimen; and
- Formula for derivation of the approximation line and its coefficient of determination.

## 17 TEST METHOD FOR TRANSVERSE SHEAR STRENGTH

### 17.1 Test Specimens

- Test specimens shall not be subjected to any processing and shall be as straight as possible. Severely bent test specimens should not be used.
- When obtaining and preparing test specimens, avoid all deformation, heating, and outdoor exposure to ultraviolet light, which can cause changes to the material properties of the test section of the test specimen.
- Test specimens shall be of constant length regardless of the nominal diameter of the FRP bars. The length shall not be less than five times the shear plane interval and not more than 300 mm.
- Test at least five test specimens. If a test specimen shows significant pull-out of fibres, indicating that failure is not due to shear, an additional test should be carried out on a separate test specimen taken from the same lot as the failed test specimen.

### 17.2 Test Equipment

The testing machine should conform to the requirements of IS 1828 (Part 1). The testing machine shall also be capable of giving readings of loading accurate to within 1 percent during the test; and the shear-testing apparatus (*see Fig. 10 to Fig. 12*) shall be constructed so that a rod-shaped test specimen is sheared on two planes more or less simultaneously by two blades (edges) converging, along the faces perpendicular to the axial direction of the test specimen. The discrepancy in the axial direction between the upper and lower blades shall be of the order of 0 mm to 0.5 mm and shall be made as small as possible. The specified distance between shear planes shall be 50 mm.

IS 18255 : 2023

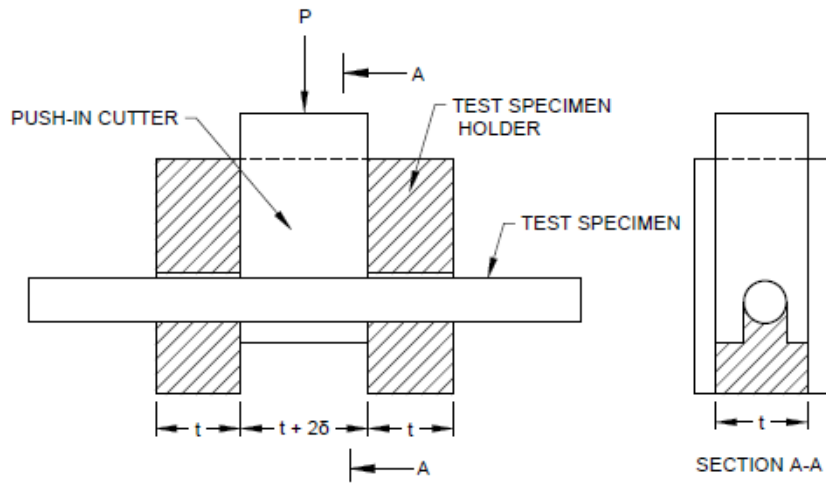

FIG. 10 DOUBLE SHEAR TEST MACHINE (TRANSVERSE SHEAR TEST)

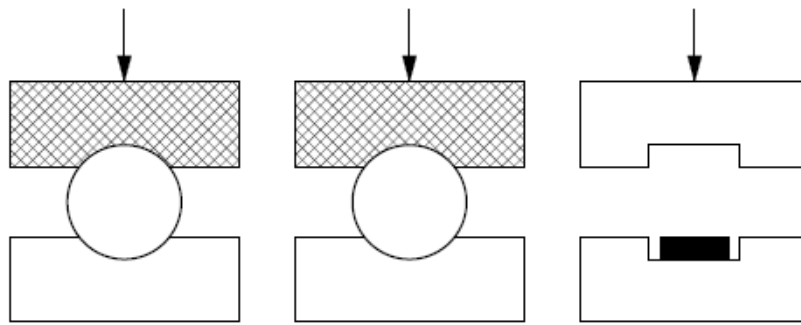

FIG. 11 COMBINATION OF TEST SPECIMENS AND TEST MACHINE CONTACT SURFACES

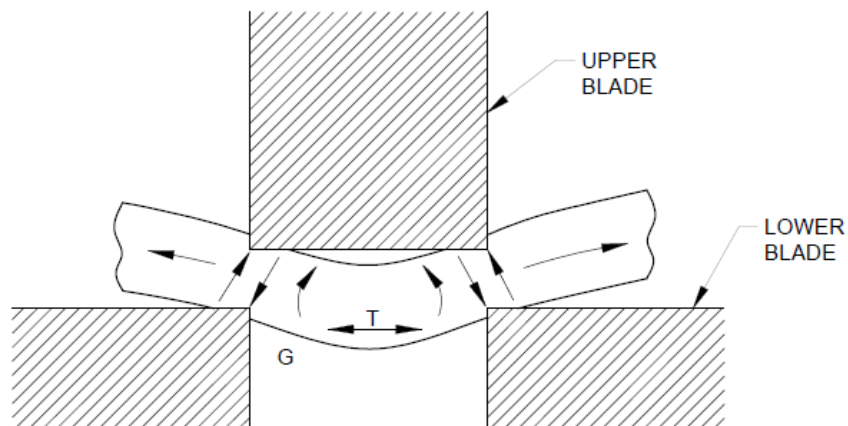

FIG. 12 CONCEPTUAL DIAGRAM OF CONTACT STRESSES FROM THE  
TEST APPARATUS ACTING ON THE TEST SPECIMEN

### 17.3 Test Procedure

- a) The ambient temperature should be within the range of  $27\text{ }^{\circ}\text{C} \pm 2\text{ }^{\circ}\text{C}$ . For cases with a significantly different field temperature, it is recommended to perform tests at a temperature similar to the field temperature.
- b) Mount the test specimen in the centre of the shear apparatus, touching the upper loading device. No gap should be visible between the contact surfaces of the loading devices.
- c) The specified loading rate shall be such that the shearing stress increases at a rate of  $30\text{ N/mm}^2/\text{min}$  to  $60\text{ N/mm}^2/\text{min}$ . Apply loading uniformly without subjecting the test specimen to shock.
- d) Continue loading until the test specimen fails. Record the failure load with a precision of three significant digits. It should be noted that loading can decrease temporarily due to the presence of two rupture faces.

### 17.4 Calculations

- a) Determine failure, whether or not it is due to shear, by visual inspection. If the pull-out of fibres is obvious, disregard the data; additional tests shall be carried out until the number of test specimens failing due to shear is not less than three.
- b) Calculate the shear strength,  $\tau_s$ , in  $\text{N/mm}^2$ , with a precision of three significant digits according to equation (23),

$$\tau_s = \frac{P_s}{2A} \quad \dots(23)$$

where

$A$  = nominal cross-sectional area of the test specimen, in  $\text{mm}^2$ ; and  
 $P_s$  = shear failure load, in N.

### 17.5 Test Report

The test report shall include the following items:

- a) Name, shape, date of manufacture, and lot number of FRP bar tested;
- b) Type of fibre and fibre-binding material;
- c) Numbers or identification marks of test specimens;
- d) Designation, nominal cross-sectional area, and diameter;
- e) Date of test, test temperature, loading rate;
- f) Interval between double shear faces and contact surface geometry;
- g) Shear failure load for each test specimen, average shear failure load and shear strength; and
- h) Failure mode of each test specimen.

## 18 TEST METHOD FOR FLEXURAL TENSILE PROPERTIES

### 18.1 Test Specimens

- a) Prepare and handle test specimens in accordance with the provisions in [11](#);
- b) The length of the test specimen shall be the length of the test section added to the length of the anchoring section. The length of the test section shall be not less than 100 mm from the anchorages to the deflected section, and not less than 40 times the nominal diameter of the FRP bar. For an FRP bar in strand form, as an additional condition, the length shall be not less than 2 times the strand pitch; and
- c) The number of test specimens shall not be fewer than five for each test condition (combination of bending diameters and bending angles). If the test specimen fails at, or slips out of, the anchoring section under the tensile capacity of 95 percent, an additional test shall be performed on a separate test specimen taken from the same lot.

### 18.2 Test Equipment

- a) The testing unit shall include a loading device, load indicator, anchorage holder, and deflector. The testing machine shall also have a structure capable of continuing the test up to the tensile failure;
- b) The loading device shall have a loading capacity in excess of the tensile capacity of the test specimen and shall be capable of applying loading at the required loading rate;
- c) The load indicator shall be capable of displaying loads with an accuracy of not less than 1 percent of the failure load, up to the failure of the test specimen;
- d) The anchorage holder shall be suited to the geometry of the test specimen and shall be capable of accurately transmitting loads from the testing machine to the test specimen. It shall be structured so as to transmit only axial loads to the test specimen, without transmitting either torsion or flexural force; and
- e) The deflector shall be capable of maintaining the required bending angle and bending diameter during the test until failure of the test specimen. The surface of the deflector in contact with the test specimen shall be robust and smooth (*see* [Fig 13](#)).

IS 18255 : 2023

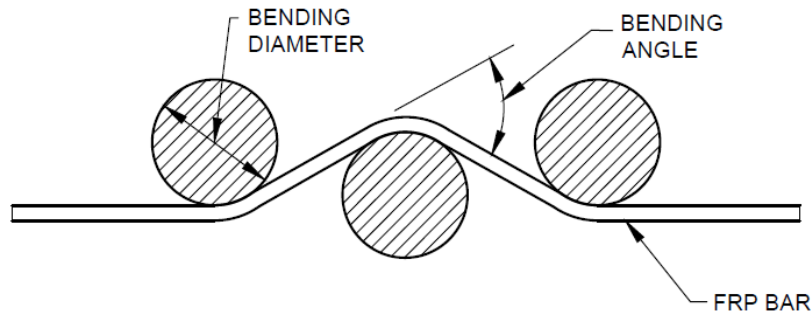

FIG. 13 EXAMPLE OF DEFLECTOR

### 18.3 Test Procedure

- a) The specified test temperature shall be  $27^{\circ}\text{C} \pm 2^{\circ}\text{C}$ .
- b) The bending diameter and bending angle shall be set appropriately for the test. This combination, then, forms a single test. As a specification configuration, only one deflected section shall be set up in the test specimen.
- c) Take care when mounting the test specimen on the testing unit to maintain the required bending angle and bending diameter at the deflected section during the test.
- d) The standard loading rate shall be a constant strain rate equivalent to 1 percent strain per minute  $\pm 0.5$  percent.
- e) Apply loading until failure of the test specimen. Measure and record the load and failure location and record the time of failure.

### 18.4 Calculations

- a) Assess the material properties of FRP bar only on the basis of test specimens undergoing failure in the test section. In cases where tensile failure or slippage has

clearly taken place at the anchoring section under the tensile capacity of 95 percent, disregard the data; and

- b) Calculate the average, maximum, and minimum bending tensile capacity for each set of test conditions.

### 18.5 Test Report

The test report shall include the following items:

- a) Name, shape, date of manufacture, and lot number of FRP bar tested;
- b) Type of fibre and fibre-binding material;
- c) Numbers or identification marks of test specimens;
- d) Designation, nominal cross-sectional area, and diameter;
- e) Date of test, test temperature, loading rate;
- f) Condition of surface of FRP bar (material, thickness, configuration, etc, of any coating);
- g) Bending angle, external diameter of surface position of deflected section, bending diameter ratio, material and surface configuration;

- h) Number of test specimens for each set of conditions in [18.5 \(g\)](#), and individual, average, maximum, and minimum bending tensile capacity; and
- j) Location and mode of failure for each test specimen.

## 19 TEST METHOD FOR THE COEFFICIENT OF LONGITUDINAL THERMAL EXPANSION BY THERMO-MECHANICAL ANALYSIS

### 19.1 Test Specimens

- a) Prior to testing, test specimens shall be kept for a minimum of 24 h at a temperature of  $27\text{ }^{\circ}\text{C} \pm 2\text{ }^{\circ}\text{C}$  and a relative humidity of  $(65 \pm 5)$  percent. The test specimens shall then normally be kept for 48 h at the maximum test temperature in order to eliminate strain resulting from bending and for dehumidification and de-aeration.
- b) The specification test specimen cut from the FRP bar shall be 20 mm in length, with a round or square cross-section having a diameter or breadth of not more than 5 mm.
- c) The number of test specimens shall not be fewer than three.

### 19.2 Test Equipment

- a) The thermomechanical analysis (TMA) apparatus used for testing shall be capable of measuring in compression mode, of maintaining a constant atmosphere around the test specimen, and of raising the temperature of the test specimen at a constant rate.
- b) Sensitivity calibration of the displacement gauge shall be carried out periodically using either an external micrometre in accordance with IS 2967, or a micrometre attached to the testing machine.
- c) Calibration of the temperature gauge shall be carried out using a pure substance of known melting point.
- d) The TMA apparatus shall be installed in a location that is not subject to vibration during testing.

### 19.3 Test Procedure

- a) Clean the test specimen, gauge rod, and test platform and place the test specimen upright and, if possible, bonded to the platform;
- b) Place the gauge rod in the centre of the test specimen, with no pressure applied;

- c) The atmosphere around the test specimen shall consist of dry air (water content not more than 0.1 percent mass fraction) or nitrogen (water content not more than 0.001 percent mass fraction, oxygen content not more than 0.001 percent mass fraction), maintained at a flow rate in the range of 500 ml/min to 100 ml/min;
- d) Apply the load gently to the tip of the gauge rod at room temperature; the temperature shall first be lowered to  $0\text{ }^{\circ}\text{C}$ , then raised to  $60\text{ }^{\circ}\text{C}$ , unless otherwise agreed, and the full process of displacement of the test specimen shall be recorded;
- e) The rate of temperature increase shall not be more than  $5\text{ }^{\circ}\text{C}/\text{min}$ ; and
- f) The compressive stress acting on the test specimen shall be around  $3\text{ mN}/\text{mm}^2$ .

### 19.4 Calculations

- a) The coefficient of thermal expansion,  $\alpha_{sp}$ , expressed in reciprocal degrees celsius, of the test specimen within the measured temperature range  $T_1$  to  $T_2$  shall be calculated according to equation (24):

$$\alpha_{sp} = (\Delta L_{spm} - \Delta L_{refm}) / [L_0 \times (T_2 - T_1)] + \alpha_{set} \quad \dots(24)$$

where

$L_0$  = length of the test specimen at room temperature, in  $\mu\text{m}$ ;

$\Delta L_{refm}$  = difference in length of the specification test specimen for length calibration between temperature  $T_1$  and temperature  $T_2$ , in  $\mu\text{m}$ ;

$\Delta L_{spm}$  = difference in the length of test specimen between temperature  $T_1$  and temperature  $T_2$ , in  $\mu\text{m}$ ;

$T_1$  = Minimum temperature for calculation of the coefficient of thermal expansion, normally  $0\text{ }^{\circ}\text{C}$ ;

$T_2$  = Maximum temperature for calculation of the coefficient of thermal expansion, normally  $60\text{ }^{\circ}\text{C}$ ; and

$\alpha_{set}$  = coefficient of thermal expansion calculated for the specification test specimen for length calibration between temperatures  $T_1$  and  $T_2$ , expressed in reciprocal degrees celsius.

## IS 18255 : 2023

- b) For apparatus in which the test specimen and specification test specimen for length calibration are measured simultaneously,  $\Delta L_{\text{refin}}$  shall be taken as equal to 0 in equation (24); and
- c) Each of the coefficients of thermal expansion shall be calculated to six decimal places ( $10^{-7}$ ), and the average value rounded off to five decimal places ( $10^{-6}$ ). If the average value is less than 1, it shall be expressed accurately to six decimal places ( $10^{-7}$ ).

### 19.5 Test Report

The test report shall include the following items:

- a) Name, shape, date of manufacture, and lot number of FRP bar tested;
- b) Type of fibre and fibre-binding material;
- c) Numbers or identification marks of test specimens;
- d) Designation, nominal cross-sectional area, and diameter;
- e) Date of test;
- f) Dimensions of test specimens;
- g) Pre-test curing method;
- h) Type of testing machine;
- j) Type of ambient atmosphere during test and flow rate;
- k) Name of substance used for temperature calibration and measurements taken;
- m) Type of specification test specimen for length calibration;
- n) Temperature range for which the coefficient of thermal expansion was measured and representative temperature;
- p) TMA curve for each test specimen; and
- q) Coefficient of thermal expansion for each test specimen and average coefficient of thermal expansion.

## 20 TEST METHOD FOR THE STRENGTH OF FRP BENT BARS AND STIRRUPS AT BEND LOCATIONS

### 20.1 Test Specimens

- a) The configuration of a typical test specimen is shown in [Fig. 14](#). The standard concrete

for bent bar test shall be made as per [12.1 \(c\)](#). The free length of the FRP bars between the two concrete blocks shall not be less than 200 mm with a suggested length of 400 mm. At least five specimens shall be tested per test condition. The test specimens shall not be subjected to any processing beyond manufacturing. The cross-sectional area of the FRP bent bar shall be the nominal cross-sectional area measured according to [10](#). Bend angle of FRP bar shall be  $(90 \pm 5)^\circ$  off of straight.

- b) Concrete blocks shall be dimensioned as shown in [Fig. 14](#). Steel stirrups are optional and may be required to prevent splitting of the concrete blocks prior to a valid FRP failure in the case of large diameter FRP bars. In case they are used, the same shall be reported. The concrete blocks shall be arranged in such a manner that each corresponding face is parallel to the other to ensure proper concentric loading of the samples.
- c) FRP bent bar dimensions are variable, but shall have a tail length,  $L_t$  of  $(12 \pm 1)$  times bar diameter per bend to minimize slippage and to help ensure a valid failure mode. To allow for easier FRP bent bar production, two C-shaped bars can also be arranged and used in the same manner as the single FRP bar shown in [Fig. 15](#) for test set-up.
- d) A debonding tube is to be used to eliminate straight bar development of the bent bar. The debonding tube shall fit over the reinforcing bar and cover the straight length of the FRP bar up to the bent portion, and shall be capped or plugged to prevent the tube from filling with concrete during casting.  

NOTE — The de-bonding tube may be made of any rigid or flexible encasement that exhibits a surface that will not bond to concrete during curing (such as PVC tubing or other suitable materials).
- e) Conditioning of samples — Condition the samples at standard laboratory temperature  $(27 \pm 2)^\circ\text{C}$  and relative humidity of  $(65 \pm 5)$  percent unless a different conditioning environment is specified as part of the experiment.

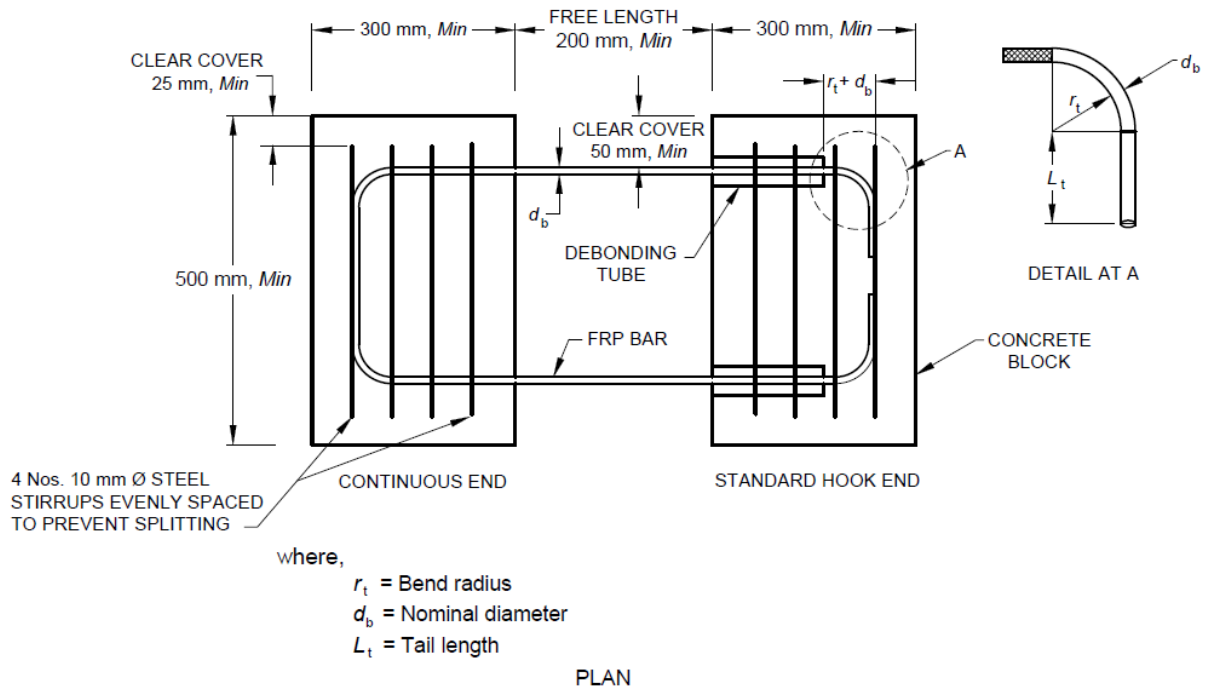

FIG. 14 FRP BENT BAR TEST SPECIMEN CONFIGURATION

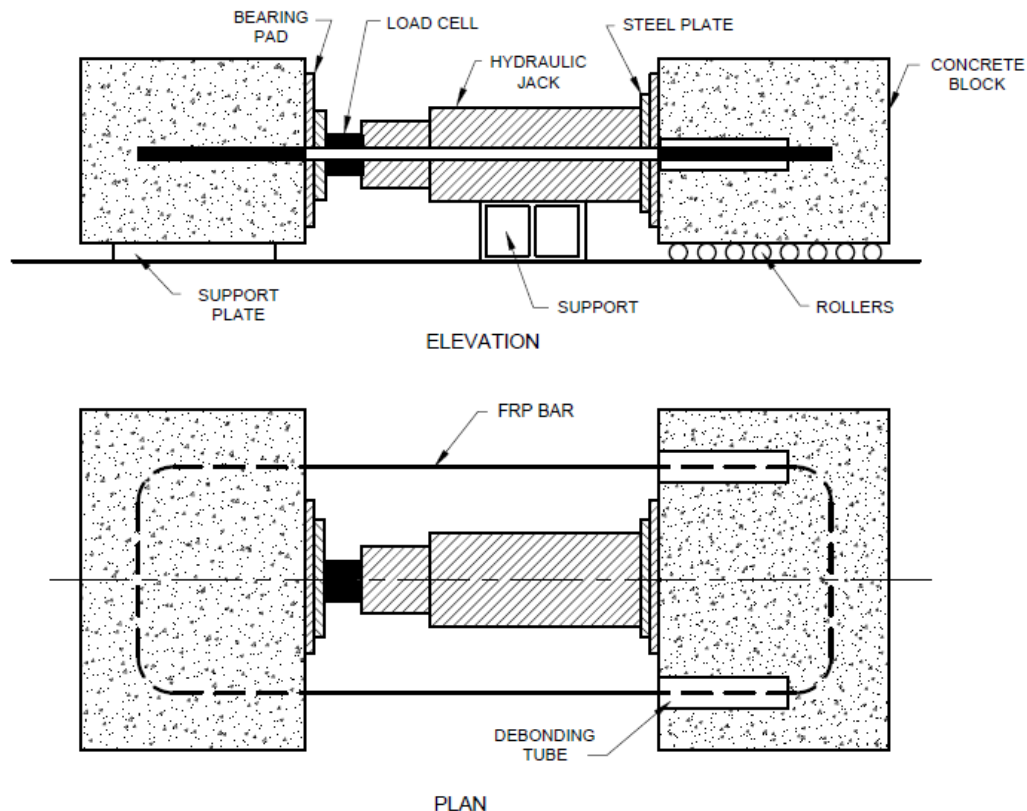

FIG. 15 SET-UP FOR THE STRENGTH OF FRP BENT BARS AND STIRRUPS AT BEND LOCATIONS

## 20.2 Test Equipment

- The test set-up shall consist of a hydraulic cylinder to distribute the applied force to the surface of the concrete.
- A plywood bearing pad of 200 mm square and at least 6 mm deep in conjunction with steel spreader plates of 100 mm square and 6 mm deep, or similar provisions shall be used at the end of the actuator to spread the force on the concrete blocks and minimize bending forces on the bent bars.
- The hydraulic cylinder shall be placed in the same plane as the FRP bars, and shall be centrally located between the legs.

## IS 18255 : 2023

- d) The block containing the test section of the bar shall be placed on top of steel rollers to minimize the friction forces between the block and testing bed.
- e) When moving the specimens, special care shall be taken to avoid damaging or displacing the cast FRP bars.

### 20.3 Loading Procedure

- a) One or more FRP bent bars, cast into two blocks of concrete, are loaded in tension until failure occurs at the bent portion of the bar. An actuation device is placed in between the two concrete blocks so that the blocks are forced apart inducing tension on the FRP bent bars.
- b) Force is recorded throughout the test.
- c) The principal variables used in the tests are the bar cross-sectional area, bend radius, and type of FRP bent bar.

### 20.4 Calculations

- a) The bend strength of the FRP bent bar shall be calculated according to equation 25 and rounded to three significant digits.

$$F_{fb} = \frac{P_{fb}}{2A} \quad \dots (25)$$

where

$A$  = nominal cross-sectional area of single leg of the FRP bent bar, as appropriate, in mm<sup>2</sup>;

$F_{fb}$  = bend strength of the FRP bent bar, in MPa; and

$P_{fb}$  = ultimate force measured in the bend test, in N.

- b) For each series of tests, calculate the average value, standard deviation, and coefficient of variation (in percent) of the resulting bend strength and strength reduction factors (ratio of bend bar strength to the straight bar strength).

### 20.5 Test Report

The test report shall include the following items:

- a) Name, shape, date of manufacture, and lot number of FRP bent bar tested;
- b) Surface characteristics of the FRP bent bar (with ribs, sand coated, plain, depression);
- c) Type of fibre and fibre-binding material;
- d) Numbers or identification marks of test specimens;

- e) Designation, nominal cross-sectional area, and diameter;
- f) Bend radius, bend angle, and tail length of FRP bent bar for each specimen;
- g) Date of test;
- h) Dimensions of test specimens;
- j) The mixture proportions of cement, fine aggregate, coarse aggregate, admixture (if used), and the water-to-cement ratio;
- k) Slump of freshly mixed concrete;
- m) 28-days strength of control concrete cubes;
- n) Type of testing machine;
- p) Calibration dates and methods for all measurement and test equipment;
- q) Test temperature and relative humidity during testing;
- r) Type and capacity of force indicator (load cell);
- s) Type and capacity of force actuator (jack);
- t) Duration of test and bend strength; and
- u) Failure mode and location of failure for each specimen.

## 21 TEST METHOD FOR LONGITUDINAL WICKING DYE PENETRATION OF SOLID FRP BAR

### 21.1 Test Specimens

- a) The length of test specimen shall be at least 25 mm taken at random locations along the FRP bar to be tested. These shall be cut dry with a diamond-dust blade to ensure a smooth test surface.
- b) In order to prevent the wicking up of the sides, paint a ring of clear polyethylene coating or other suitable inhibitor below the top surface and around the circumference of each test specimen.
- c) Test specimens shall not be taken from material that has been damaged or subjected to previous testing.
- d) The number of test specimens shall not be fewer than five.

### 21.2 Test Equipment

- a) *Dye Penetrant*;
- b) *Ultraviolet light source*, a black lamp light source, as the penetrant used is fluorescent;
- c) *Dark room*, an area for viewing the presence of fluorescent spots on the test specimens;

- d) *Hood*, for providing adequate air ventilation for the elimination of any annoying vapours from the penetrant. These vapours are non-toxic, but has potential to be an irritant;
- e) *Shallow pan*, for holding the penetrant such as a thin, spongy material that can be placed in the pan to support the specimen on one end;
- f) *Stop watch*, or other means for timing the length of the test; and
- g) *Magnifying glass*, 5X, recommended for identifying very small fluorescent specks, or dots, on the specimen's upper face. It is not regarded as essential.

### 21.3 Testing Procedure

- a) Condition the test specimens at  $27\text{ }^{\circ}\text{C} \pm 2\text{ }^{\circ}\text{C}$  and 65 percent  $\pm 5$  percent relative humidity for not less than 40 h prior to test;
- b) Test conditions — Conduct all testing in the standard laboratory atmosphere of  $27\text{ }^{\circ}\text{C} \pm 2\text{ }^{\circ}\text{C}$  and 65 percent  $\pm 5$  percent relative humidity, unless otherwise specified;
- c) Preheat the ultraviolet light source for 15 min or in accordance with the manufacturer's recommendations. Position the light to shine on the pan (penetrant) surface;
- d) Place a thin, spongy material such as common household plastic foam sponge on the bottom of the pan to support the specimens. This material aids in properly wetting the bottom surface of the specimen and reduces possible problems associated with air entrapment;
- e) Add sufficient dye to the pan such that the specimens are immersed to a depth of 3.2 mm while resting on the sponge. This depth shall be predetermined with an extra piece of FRP bar;
- f) Place each specimen on end in the penetrant to the depth specified in SI No. (e) and staggered from the rest of the group. The actual time of immersion for each shall be recorded if more than six specimens are to be tested at one time. Otherwise, all specimens shall be considered to be immersed at the same time. When more than six specimens are to be tested, an interval of 30 s between the respective immersions shall be observed. For example, if a group of nine specimens are to be tested, one can be added at  $T = 0$ , the next at  $T = 30$  s, and the last at  $T = 4.0$  min;
- g) Immerse each specimen such that its lower face is inserted into the dye normal to the supporting sponge to ensure optimum coating of its surface. Press down lightly on the upper face of the specimen to effect its positive sealing;
- h) Position the specimens in the penetrant in a row left to right such that the first, second, etc can be easily identified;
- j) Record the time for the appearance of the first dot;
- k) Count upper face wicking dots (fluorescent specks) following 30 min of penetrant immersion. For a large group of specimens, the counting shall be completed between 29 min 45 s and 30 min 15 s for each specimen;
- m) The immersion time of 30 min for all specimens is particularly critical and shall be observed within the limits specified above (*see* step k), if meaningful data are to be obtained;
- n) If an error is made, or if a specimen falls into the penetrant, reject that specimen and run a retest from retained specimens;
- p) Record the time to the first dot. Record the total number of wicking dots or specks, for each specimen after 30 min immersion, discounting those that have merged as one. If the latter condition exists, discontinue the test for that particular specimen and test another; and
- q) Avoid hand contact with the penetrant to preclude possible contamination of the specimens during handling. Wash hands thoroughly before proceeding, if contact with the penetrant occurs.

## IS 18255 : 2023

### 21.4 Calculations

Record the time and count the number of wicking dots/void for each specimen after immersing/positioning it in the penetrant.

### 21.5 Test Report

- a) Name, shape, date of manufacture, and lot number of FRP bar tested;
- b) Type of fibre and fibre-binding material;
- c) Numbers or identification marks of test specimens;
- d) Designation, nominal cross-sectional area, and diameter;
- e) Date of test;
- f) Dimensions of test specimens;
- g) Pre-test curing method;
- h) Individual specimens tested, with individual wicking dots;
- j) The average of the individual wicking dots for each sample; and
- k) Any deviations from the test method shall be included, such as alternate penetrant source, etc.

## ANNEX A

### [[Clause 11.2 \(b\)](#)]

#### ANCHORING OF FRP BARS FOR TENSILE TESTING

**A-1** FRP bars shall be properly anchored prior to the tensile testing to avoid premature failure of FRP bars at the junctions. Guidelines for anchoring FRP bars using steel anchors are given in [A-2](#) to [A-5](#).

##### A-2 STEEL ANCHORS

- Steel tubes of required dimensions shall be used for anchoring purpose given in [Table 4](#);
- Steel tubes are equipped with the polyvinyl chloride (PVC) cap that has a concentric through-hole of appropriate diameter used to centre FRP bars inside the steel tube;
- Then the steel plug with a concentric through-hole may be either threaded or welded to the steel tube. An anchor sample is shown below; and
- Mechanical treatment, chemical treatment, or cleaning of the inner surface of the tube to promote adhesion of the tube with the casting resin or grout is acceptable, provided that it does not affect the tensile properties of the specimen in the free length portion (*see* [Fig. 16](#)).

##### A-3 ANCHOR FILLER MATERIALS

- The tube may be filled with either polymer resin or a 1 : 1 mixture by weight of resin and clean sand or an expansive cement grout;
- A filler material compatible with the resin of which the specimen is made should be used; and
- The strength of the filler should be such that the maximum tensile force occurring during a test does not cause slip throughout the entire bonded length of the specimen.

##### A-4 IMPORTANT POINTS TO BE FOLLOWED

- A wall thickness of 4.8 mm or greater is recommended.
- A minimum grout space of 4 mm is recommended between the outer surface of the bar and the inner wall of the steel tube.
- Anchor length  $L_a$  is the length required to bond the bar to the steel tube; overall length

may need to be increased for use with threaded plugs as shown in the figure in the [Table 4](#).

- The free length between the anchors,  $L$ , should be not less than 380 mm nor less than 40 times the effective bar diameter,  $d$ .

##### A-5 TEST SPECIMEN PREPARATION

###### A-5.1 Proper Alignment of FRP Bars

- The steel tubes and the FRP bar should be axially aligned before the grout or resin is applied;
- [Figure 17](#) depicts a suitable fixture that may be used to achieve this alignment;
- In the fixture depicted, a steel plug is threaded to the steel tube;
- The FRP bar goes through the concentric hole of the steel plug and through the PVC cap and is thus held axially aligned inside the tube;
- Silicon caulking is applied at the bottom of the plug so as to prevent any possible leakage of resin or grout; and
- Alternative alignment fixtures and sealing methods are acceptable.

###### A-5.2 Casting

- Align the FRP bar vertically with respect to steel anchors;
- The resin or grout should be poured to the required level directly from a beaker with a narrow spout, or by means of a funnel with a suitable stem;
- Lightly tap the outside of the tube to remove any entrapped air pocket inside;
- And then slide the PVC cap on the rod down and tap onto the top of the tube immediately;
- If the specimen needs anchors at both ends, at least 12 h should elapse before the first anchor is flipped to cast the other anchor; and
- The curing schedule recommended by the manufacturer of the filler material should be allowed before testing to allow the resin or grout to set inside the tube.

NOTE — When not held vertically, the anchored specimen should be handled by holding both grips to avoid bending or twisting of the specimen.

IS 18255 : 2023

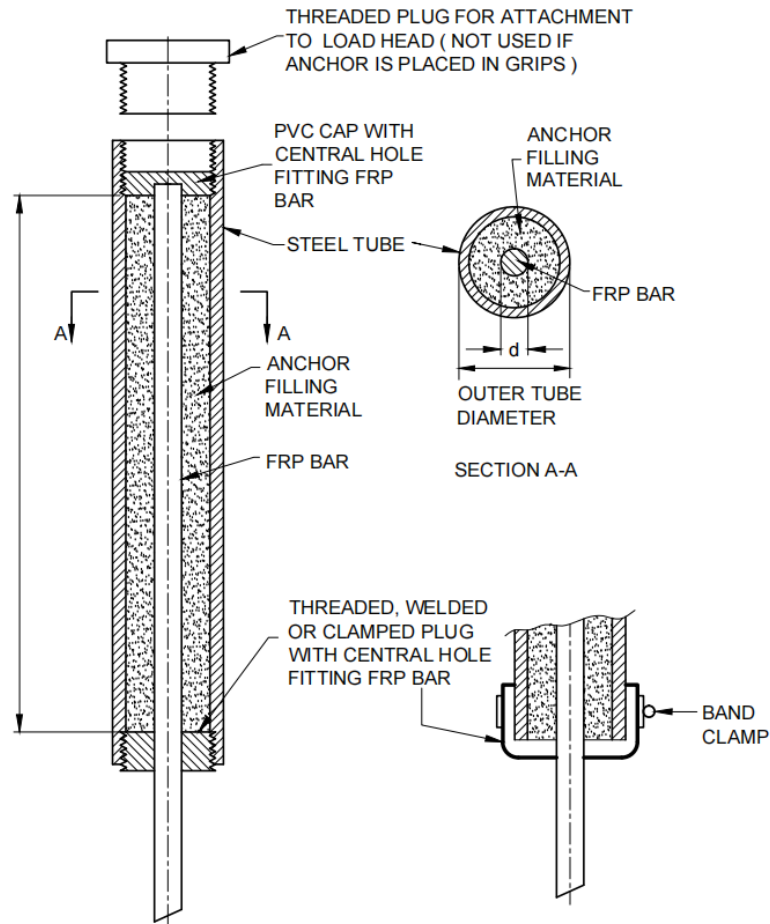
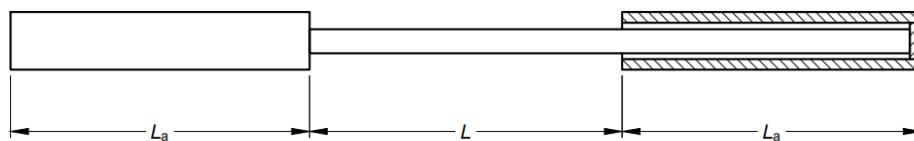

FIG. 16 TYPICAL ANCHOR DETAILS

**Table 4 Recommended Dimensions of Test Specimens and Steel Tubes**

(Clauses [A-2](#) and [A-4](#))



Sl No.	Diameter of the FRP Bar, $d$ mm	Outside Diameter of the Steel Tube mm	Minimum Length of the Steel Tube, $L_a$ mm
(1)	(2)	(3)	(4)
i)	4	35	300
ii)	6	35	300
iii)	8	35	300
iv)	10	35	300
v)	12	42	380
vi)	16	42	380
vii)	20	48	460
viii)	25	48	460
ix)	32	75	800

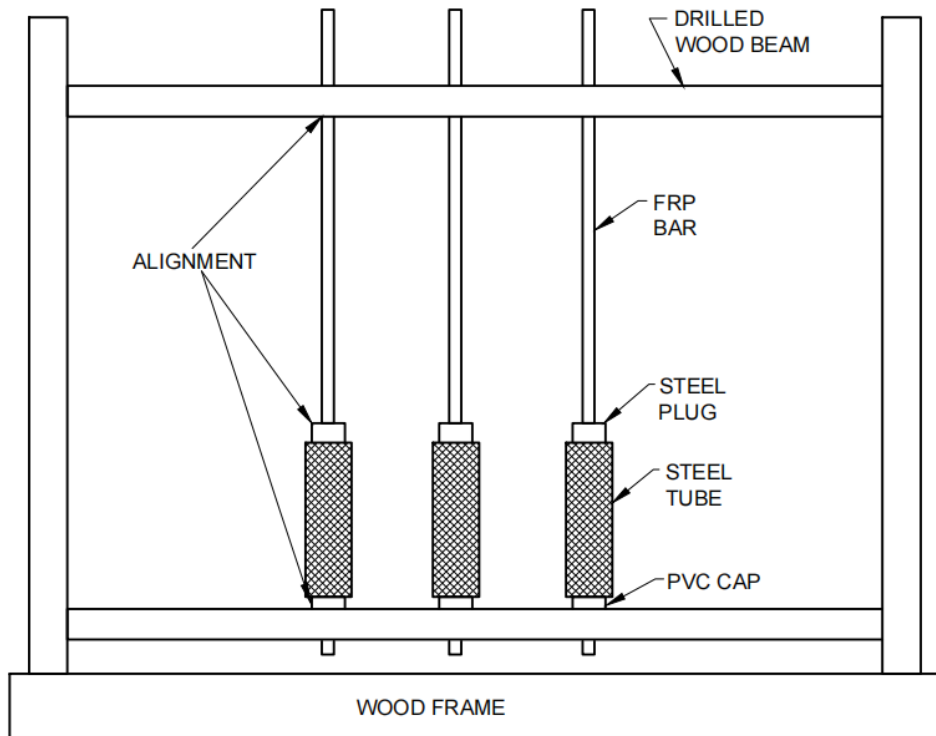

FIG. 17 JIG TO ALIGN SPECIMENS AND ANCHORS

IS 18255 : 2023

**ANNEX B**

*(Foreword)*

**COMMITTEE COMPOSITION**

Concrete Reinforcement Sectional Committee, CED 54

<i>Organization</i>	<i>Representative(s)</i>
In Personal Capacity (No. 17, Nalanda Apartments, D-Block, Vikaspuri, New Delhi - 110018)	SHRI G. SHARAN ( <b>Chairperson</b> )
Central Public Works Department, New Delhi	SHRI A. K. RAJDEV SHRI SAUROBH KUMAR ( <i>Alternate</i> )
Central Water Commission, New Delhi	DIRECTOR (HCD-NW&S) DIRECTOR (HCD-N&W) ( <i>Alternate</i> )
Construction Industry Development Council, New Delhi	SHRI SUNIL MAHAJAN SHRI O. P. GUPTA ( <i>Alternate</i> )
CSIR - Central Building Research Institute, Roorkee	DR S. R. KARADE DR R. SIVA CHIDAMBARAM ( <i>Alternate</i> )
CSIR - Central Electrochemical Research Institute, Karaikudi	SHRI K. SARAVANAN DR J. DANIEL RONALD JOSEPH ( <i>Alternate I</i> ) DR M. ASHOK ( <i>Alternate II</i> )
CSIR - Central Road Research Institute, New Delhi	DR RAJEEV GOEL SHRI S. S. GAHARWAR ( <i>Alternate</i> )
CSIR - National Metallurgical Laboratory, Jamshedpur	REPRESENTATIVE
CSIR - Structural Engineering Research Centre, Chennai	DR B. H. BHARATH KUMAR DR SMITHA GOPINATH ( <i>Alternate</i> )
Delhi Development Authority, New Delhi	CHIEF ENGINEER (DESIGN) SUPERINTENDING ENGINEER (DESIGN) II/CDO ( <i>Alternate</i> )
Delhi Metro Rail Corporation, New Delhi	SHRI NAVNEET KUMAR KOTHARI SHRI SANJEEV KUMAR GARG ( <i>Alternate</i> )
Delhi Tourism and Transportation Development Corporation Ltd, New Delhi	SHRI SHISHIR BANSAL
Dextra India Pvt Ltd, Mumbai	SHRI SUNIL DESAI SHRI JITENDRA H. PATHAK ( <i>Alternate</i> )
Engineers India Limited, New Delhi	SHRI ANURAG SINHA SHRI DEEPAK AGRAWAL ( <i>Alternate I</i> ) SHRI VISHAL KUMAR ( <i>Alternate II</i> )
Gammon Engineers and Contractors Pvt Ltd, Mumbai	SHRI ANIRWAN SENGUPTA SHRI GIRISH JOSHI ( <i>Alternate</i> )
Hindustan Construction Company, Mumbai	SHRI MUKESH VALECHA

<i>Organization</i>	<i>Representative(s)</i>
Indian Association of Structural Engineers, New Delhi	SHRI HARI OM GUPTA SHRI MANOJ K. MITTAL ( <i>Alternate</i> )
Indian Institute of Technology Delhi, New Delhi	DR DIPTI RANJAN SAHOO PROF B. BHATTACHARJEE ( <i>Alternate</i> )
Indian Institute of Technology Hyderabad, Hyderabad	DR SURIYA PRAKASH DR MEENAKSHI SHARMA ( <i>Alternate</i> )
Indian Institute of Technology Madras, Chennai	DR RADHAKRISHNA G. PILLAI DR RUPEN GOSWAMI ( <i>Alternate</i> )
Indian Institute of Technology Roorkee, Roorkee	PROF PRAMOD KUMAR GUPTA PROF AKHIL UPADHYAY ( <i>Alternate</i> )
Indian Stainless Steel Development Association, New Delhi	SHRI ROHIT KUMAR SHRI KARAN KUMAR PAHUJA ( <i>Alternate</i> )
Institute of Steel Development and Growth (INSDAG), Kolkata	SHRI LAKSHMANA RAO PYDI SHRI SAJAL KUMAR GHORAI ( <i>Alternate</i> )
IRCON Ltd, New Delhi	SHRI ROHIT KHANNA SHRI NRIPENDRA KUMAR ROY ( <i>Alternate</i> )
Jindal Steel and Power Ltd, New Delhi	SHRI AJAY AGARWAL SHRI S. K. PRADHAN ( <i>Alternate</i> )
JSW Steel Ltd, Raigad	SHRI PRATAP K. PATRA
Larsen and Toubro Ltd (ECC Construction Division), Chennai	SHRI S. KANAPPAN SHRI STHALADIPTI SAHA ( <i>Alternate</i> )
Military Engineer Services, Engineer-in-Chief's Branch, Integrated HQ of MOD (Army), New Delhi	SHRI P. K. JAIN SHRI SOMESH KUMAR ( <i>Alternate</i> )
Ministry of Road Transport & Highways, New Delhi	DR S. K. VERMA DR SANJAY WAKCHAURE ( <i>Alternate</i> )
Ministry of Steel, New Delhi	SHRI S. K. BHATNAGER SHRI ANIL KUMAR MISHRA ( <i>Alternate</i> )
National Council for Cement and Building Materials, Ballabgarh	SHRI P. N. OJHA SHRI AMIT TRIVEDI ( <i>Alternate I</i> ) SHRI BRIJESH SINGH ( <i>Alternate II</i> )
National Highways and Infrastructure Development Corporation Ltd, New Delhi	REPRESENTATIVE
National Highways Authority of India, New Delhi	SHRI R. K. PANDEY SHRI S. K. MISHRA ( <i>Alternate</i> )

**IS 18256 : 2023**

<i>Organization</i>	<i>Representative(s)</i>
National Institute of Secondary Steel Technology, Mandi Gobindgarh	SHRI RAJIB KUMAR PAUL SHRI SANDEEP PAL SINGH ( <i>Alternate</i> )
NBCC (India) Ltd, New Delhi	SHRI ARUN KUMAR SHARMA SHRI PRANAY JAIN ( <i>Alternate</i> )
Nirma University, Ahmedabad	DR URMIL V. DAVE
NTPC Limited, Noida	SHRI S. KHADANGA SHRI A. P. SRIVASTAVA ( <i>Alternate</i> )
Nuclear Power Corporation India Limited, Mumbai	SHRI Y. T. PRAVEENCHANDRA SHRI R. N. SARANGI ( <i>Alternate</i> )
P.S.L. Limited, Mumbai	SHRI R. RADHAKRISHNAN SHRI RAMNATH BHAT ( <i>Alternate</i> )
Rashtriya Ispat Nigam Ltd, Vizag	SHRI C. H. SRINIVASA RAO SHRI G. RAJA LINGAM ( <i>Alternate</i> )
Research Design and Standards Organization, Ministry of Railways, Lucknow	SHRI MAHENDRA PRATAP SINGH SHRI ASHOK KUMAR PANDEY ( <i>Alternate</i> )
Steel Authority of India Limited, Durgapur Steel Plant, Durgapur	SHRI A. N. BANARJEE SHRI ABHIJIT DATTA ( <i>Alternate</i> )
Steel Authority of India Limited, R&D Centre for Iron & Steel, Ranchi	DR V. KUMAR DR P. SARAVANAN ( <i>Alternate</i> )
Steel Re-Rolling Mills Association of India, Kolkata	SHRI B. M. BERIWALA SHRI SWAPAN KUMAR CHAKRAVORTY ( <i>Alternate</i> )
STUP Consultants Pvt Limited, Mumbai	SHRI AMIT KUMAR CHAKRABORTY SHRI ANIRBAN SENGUPTA ( <i>Alternate</i> )
Sunflag Iron and Steel Co Ltd, New Delhi	SHRI R. K. MALHOTRA SHRI JAGANNATHAN SOMU ( <i>Alternate</i> )
Tata Steel Ltd, Jamshedpur	SHRI BISWAJIT GHOSH DR ANUP KUMAR ( <i>Alternate</i> )
Tata Steel Global Wires, Mumbai	SHRI SHISHIR V. DESAI SHRI SURESH MAHAJAN ( <i>Alternate</i> )
Weldmesh Manufacturer's Association, Mumbai	SHRI VIJAY LACHMANDAS DODEJA SHRI ZAKIR NISSAR AHMED ( <i>Alternate I</i> ) SHRI BIPIN KEDIA ( <i>Alternate II</i> )
In Personal Capacity ( <i>House No. 131, Sector 11D, Faridabad - 121006</i> )	SHRI V. V. ARORA
In Personal Capacity ( <i>CJ-331 Salt Lake City, Kolkata - 700091</i> )	DR ANIL K. KAR

<i>Organization</i>	<i>Representative(s)</i>
BIS Directorate General	SHRI ARUNKUMAR S., SCIENTIST 'E'/DIRECTOR AND HEAD (CIVIL ENGINEERING) [REPRESENTING DIRECTOR GENERAL ( <i>Ex-officio</i> )]

*Member Secretary*  
SHRIMATI MADHURIMA MADHAV  
SCIENTIST 'D'/JOINT DIRECTOR  
(CIVIL ENGINEERING), BIS

Working Group for Formulation of Standards for FRP Bars, CED 54/WG 5

<i>Organization</i>	<i>Representative(s)</i>
Indian Institute of Technology Madras, Chennai	DR RADHAKRISHNA G. PILLAI ( <i>Convener</i> )
Arc Insulations and Insulators Pvt Ltd, Kolkata	SHRI MANISH BAJORIA
CSK Technologies, Hyderabad	SHRI LAXMAN SOMA
Indian Institute of Technology Bombay, Mumbai	PROF ARGHADEEP LASHKAR
Indian Institute of Technology Hyderabad, Hyderabad	PROF SURIYA PRAKASH
MRG Composites India Pvt Ltd, Rajkot	SHRI AMIT GANGURDE
National Council for Cement & Building Materials, Ballabgarh	SHRI P. N. OJHA SHRI AMIT TRIVEDI ( <i>Alternate I</i> ) SHRI BRIJESH SINGH ( <i>Alternate II</i> )
National Institute of Technology Tiruchirappalli, Tiruchirappalli	DR PRABHA MOHANDOSS
Quad Composites Pvt Ltd, Aurangabad	SHRI AMRIT SANGHAI SHRIMATI KETKI SANGHAI ( <i>Alternate</i> )
In Personal Capacity ( <i>House No. 131, Sector 11D, Faridabad - 121006</i> )	SHRI V. V. ARORA

This Page has been Intentionally left blank

This Page has been Intentionally left blank

## Bureau of Indian Standards

BIS is a statutory institution established under the *Bureau of Indian Standards Act, 2016* to promote harmonious development of the activities of standardization, marking and quality certification of goods and attending to connected matters in the country.

### Copyright

BIS has the copyright of all its publications. No part of these publications may be reproduced in any form without the prior permission in writing of BIS. This does not preclude the free use, in the course of implementing the standard, of necessary details, such as symbols and sizes, type or grade designations. Enquiries relating to copyright be addressed to the Head (Publication & Sales), BIS.

### Review of Indian Standards

Amendments are issued to standards as the need arises on the basis of comments. Standards are also reviewed periodically; a standard along with amendments is reaffirmed when such review indicates that no changes are needed; if the review indicates that changes are needed, it is taken up for revision. Users of Indian Standards should ascertain that they are in possession of the latest amendments or edition by referring to the website-[www.bis.gov.in](http://www.bis.gov.in) or [www.standardsbis.in](http://www.standardsbis.in).

This Indian Standard has been developed from Doc No.: CED 54 (18904).

### Amendments Issued Since Publication

Amend No.	Date of Issue	Text Affected

## BUREAU OF INDIAN STANDARDS

### Headquarters:

Manak Bhavan, 9 Bahadur Shah Zafar Marg, New Delhi 110002  
Telephones: 2323 0131, 2323 3375, 2323 9402

Website: [www.bis.gov.in](http://www.bis.gov.in)

### Regional Offices:

	Telephones
Central : 601/A, Konnectus Tower -1, 6 <sup>th</sup> Floor, DMRC Building, Bhavbhuti Marg, New Delhi 110002	{ 2323 7617
Eastern : 8 <sup>th</sup> Floor, Plot No 7/7 & 7/8, CP Block, Sector V, Salt Lake, Kolkata, West Bengal 700091	{ 2367 0012 2320 9474
Northern : Plot No. 4-A, Sector 27-B, Madhya Marg, Chandigarh 160019	{ 265 9930
Southern : C.I.T. Campus, IV Cross Road, Taramani, Chennai 600113	{ 2254 1442 2254 1216
Western : Plot No. E-9, Road No.-8, MIDC, Andheri (East), Mumbai 400093	{ 2821 8093

**Branches :** AHMEDABAD. BENGALURU. BHOPAL. BHUBANESHWAR. CHANDIGARH. CHENNAI. COIMBATORE. DEHRADUN. DELHI. FARIDABAD. GHAZIABAD. GUWAHATI. HIMACHAL PRADESH. HUBLI. HYDERABAD. JAIPUR. JAMMU & KASHMIR. JAMSHEDPUR. KOCHI. KOLKATA. LUCKNOW. MADURAI. MUMBAI. NAGPUR. NOIDA. PANIPAT. PATNA. PUNE. RAIPUR. RAJKOT. SURAT. VISAKHAPATNAM.